



L&T CAST STEEL GATE, GLOBE & CHECK VALVES

**ASME Class 150 - 2500
50mm - 1600mm (2" - 64")**

API 600 • BS 1873 • BS 1868

API 603

ASME B16.34



L&T Valves Limited

ASME
VALVES
L&T

L&T Cast Steel Gate, Globe and Check Valves have established themselves the world over for their quality, reliability and long service. The valves are manufactured to the latest international designs, using advanced manufacturing techniques and stringent quality control checks. The valves are regularly supplied to major Indian and international clients including oil refining companies and EPC contractors. A wide network of distributors ensures the availability of L&T valves anywhere in the world.

L&T Valves Limited is a leading valve manufacturer, with a strong presence in India and overseas.

The company has two manufacturing facilities located in Southern India - in Manapakkam, Chennai and Kancheepuram. The plants are equipped with modern manufacturing facilities including special-purpose machines, automatic welding equipment, heat treatment furnaces and testing equipment for total control of all manufacturing operations. In-house metallurgical and NDE laboratories and calibration facilities with modern equipment provide support to ensure the quality of products manufactured.

L&T manufactures a wide variety of industrial valves. The Quality Management System of the plants is certified to comply with ISO 9001:2008.

Table of Contents

Content	Page No.
Introduction	02 - 05
<i>Manufacturing Programme</i>	03
<i>Common Test / Inspection methods</i>	04
<i>Test Pressures for standard Carbon Steel Valves</i>	04
<i>Compliance Standards</i>	05
<i>Body / Bonnet Materials</i>	05
API 600 / BS 1873 / BS 1868	
Gate, Globe & Swing Check Valves	06 - 15
<i>Salient Features</i>	06, 07
<i>Bonnet Gaskets</i>	08
<i>Trim Material</i>	09
<i>Stem Packing</i>	09
<i>Ordering Information</i>	09
<i>Gate Valves (CI 150, 300 & 600)</i>	10
<i>Gate Valves (CI 900 & 1500)</i>	11
<i>Globe Valves (CI 150, 300 & 600)</i>	12
<i>Globe Valves (CI 900 & 1500)</i>	13
<i>Swing Check Valves (CI 150, 300 & 600)</i>	14
<i>Swing Check Valves (CI 900 & 1500)</i>	15
API 603 Stainless Steel Gate Valves	16 & 17
<i>Salient Features</i>	16
<i>Stainless Steel Gate Valves (CI 150 & 300)</i>	17
ASME B16.34	
Gate, Y-Globe & Swing Check Valves	18 - 21
<i>Salient Features</i>	18, 19
<i>Pr. Seal Bonnet Gate Valves (CI 900, 1500 & 2500)</i>	20
<i>Pr. Seal Bonnet Y-Globe Valves (CI 1500)</i>	21
<i>Pr. Seal Bonnet Swing Check Valves (CI 900, 1500 & 2500)</i>	21
Cryogenic Valves	22 & 23
Angle Globe Valves	24
Special Valves	25
Technical Information	26 - 29
<i>Pressure-Temperature Ratings</i>	26, 27
<i>End Flange Dimensions-CI 150 & 300 - RF</i>	28
<i>Large-sized End Flange Dimensions - CI 150 & 300 - RF</i>	28
<i>End Flange Dimensions-CI 600 - RF / RTJ</i>	28
<i>End Flange Dimensions-CI 900 - RF / RTJ</i>	28
<i>End Flange Dimensions-CI 1500 - RF / RTJ</i>	28
<i>Butt-weld end Details and Dimensions</i>	29
<i>Cast Steel - Material Characteristics</i>	29
Valve Accessories	30
Reputed Clientele	31



L&T Manufacturing Programme

Quality Policy

L&T Valves Limited is committed to Total Customer Satisfaction

We achieve this by

- Maintaining a high standard of quality consistent with the customer requirements
- Complying with the Codes, Standards, Customer Specifications, Statutory and Regulatory requirements as applicable to our Products
- Continually improving the effectiveness of Quality Management System to add value to our Products

		Valve type	End Conn.	ASME Class	2	2½	3	4	5	6	8	10	12	14	16	18	20	24	28	30	34	36	42	48	60				
DESIGN STANDARD & WALL THICKNESS	API 600 & BS 1414	Gate Valves Bolted Bonnet Flex Wedge	Flanged	150	•	•	•	•	•	•	•	•	•	•	•	•	•	•	•	•	•	•	•	•	•	•			
				300	•	•	•	•	•	•	•	•	•	•	•	•	•	•	•	•	•	•	•	•	•	•	•	•	
				600	•	•	•	•	•	•	•	•	•	•	•	•	•	•	•	•	•	•	•	•	•	•	•	•	•
				900	•	•	•	•	•	•	•	•	•	•	•	•	•	•	•	•	•	•	•	•	•	•	•	•	•
				1500	•	•	•	•	•	•	•	•	•	•	•	•	•	•	•	•	•	•	•	•	•	•	•	•	•
			Buttweld ends	150	•	•	•	•	•	•	•	•	•	•	•	•	•	•	•	•	•	•	•	•	•	•	•	•	•
				300	•	•	•	•	•	•	•	•	•	•	•	•	•	•	•	•	•	•	•	•	•	•	•	•	•
				600	•	•	•	•	•	•	•	•	•	•	•	•	•	•	•	•	•	•	•	•	•	•	•	•	•
				900	•	•	•	•	•	•	•	•	•	•	•	•	•	•	•	•	•	•	•	•	•	•	•	•	•
				1500	•	•	•	•	•	•	•	•	•	•	•	•	•	•	•	•	•	•	•	•	•	•	•	•	•
	BS 1873	Globe Valves Bolted Bonnet Plug/Ball type Disc	Flanged	150	•	•	•	•	•	•	•	•	•	•	•	•	•	•	•	•	•	•	•	•	•	•	•	•	
				300	•	•	•	•	•	•	•	•	•	•	•	•	•	•	•	•	•	•	•	•	•	•	•	•	•
				600	•	•	•	•	•	•	•	•	•	•	•	•	•	•	•	•	•	•	•	•	•	•	•	•	•
				900	•	•	•	•	•	•	•	•	•	•	•	•	•	•	•	•	•	•	•	•	•	•	•	•	•
				1500	•	•	•	•	•	•	•	•	•	•	•	•	•	•	•	•	•	•	•	•	•	•	•	•	•
Buttweld ends			150	•	•	•	•	•	•	•	•	•	•	•	•	•	•	•	•	•	•	•	•	•	•	•	•	•	
			300	•	•	•	•	•	•	•	•	•	•	•	•	•	•	•	•	•	•	•	•	•	•	•	•	•	
			600	•	•	•	•	•	•	•	•	•	•	•	•	•	•	•	•	•	•	•	•	•	•	•	•	•	
			900	•	•	•	•	•	•	•	•	•	•	•	•	•	•	•	•	•	•	•	•	•	•	•	•	•	
			1500	•	•	•	•	•	•	•	•	•	•	•	•	•	•	•	•	•	•	•	•	•	•	•	•	•	
BS 1868	Check Valves Bolted Cover Swing type Disc	Flanged	150	•	•	•	•	•	•	•	•	•	•	•	•	•	•	•	•	•	•	•	•	•	•	•	•		
			300	•	•	•	•	•	•	•	•	•	•	•	•	•	•	•	•	•	•	•	•	•	•	•	•		
			600	•	•	•	•	•	•	•	•	•	•	•	•	•	•	•	•	•	•	•	•	•	•	•	•	•	
			900	•	•	•	•	•	•	•	•	•	•	•	•	•	•	•	•	•	•	•	•	•	•	•	•	•	
			1500	•	•	•	•	•	•	•	•	•	•	•	•	•	•	•	•	•	•	•	•	•	•	•	•	•	
		Buttweld ends	150	•	•	•	•	•	•	•	•	•	•	•	•	•	•	•	•	•	•	•	•	•	•	•	•	•	
			300	•	•	•	•	•	•	•	•	•	•	•	•	•	•	•	•	•	•	•	•	•	•	•	•	•	
			600	•	•	•	•	•	•	•	•	•	•	•	•	•	•	•	•	•	•	•	•	•	•	•	•	•	
			900	•	•	•	•	•	•	•	•	•	•	•	•	•	•	•	•	•	•	•	•	•	•	•	•	•	
			1500	•	•	•	•	•	•	•	•	•	•	•	•	•	•	•	•	•	•	•	•	•	•	•	•	•	
API 603	Gate Valves Bolted Bonnet	Flanged	150	•	•	•	•	•	•	•	•	•	•	•	•	•	•	•	•	•	•	•	•	•	•	•	•		
		300	•	•	•	•	•	•	•	•	•	•	•	•	•	•	•	•	•	•	•	•	•	•	•	•	•		
	ASME B16.34	Gate Valves Pr. Seal Bonnet Parallel Slide Disc	Buttweld ends	900	•	•	•	•	•	•	•	•	•	•	•	•	•	•	•	•	•	•	•	•	•	•	•	•	
			1500	•	•	•	•	•	•	•	•	•	•	•	•	•	•	•	•	•	•	•	•	•	•	•	•	•	
		Globe Valves Pr. Seal Bonnet Plug type Disc	Buttweld ends	900	•	•	•	•	•	•	•	•	•	•	•	•	•	•	•	•	•	•	•	•	•	•	•	•	
			1500	•	•	•	•	•	•	•	•	•	•	•	•	•	•	•	•	•	•	•	•	•	•	•	•	•	
		Check Valves Pr. Seal Bonnet Swing type	Buttweld ends	900	•	•	•	•	•	•	•	•	•	•	•	•	•	•	•	•	•	•	•	•	•	•	•	•	
			1500	•	•	•	•	•	•	•	•	•	•	•	•	•	•	•	•	•	•	•	•	•	•	•	•	•	
			2500	•	•	•	•	•	•	•	•	•	•	•	•	•	•	•	•	•	•	•	•	•	•	•	•	•	
			2500	•	•	•	•	•	•	•	•	•	•	•	•	•	•	•	•	•	•	•	•	•	•	•	•	•	
OTHER VALVES	CRYOGENIC	Cryogenic Gate Valves	150	•	•	•	•	•	•	•	•	•	•	•	•	•	•	•	•	•	•	•	•	•	•	•	•		
			300	•	•	•	•	•	•	•	•	•	•	•	•	•	•	•	•	•	•	•	•	•	•	•	•	•	
			600	•	•	•	•	•	•	•	•	•	•	•	•	•	•	•	•	•	•	•	•	•	•	•	•	•	
		Cryogenic Globe Valves	150	•	•	•	•	•	•	•	•	•	•	•	•	•	•	•	•	•	•	•	•	•	•	•	•	•	
			300	•	•	•	•	•	•	•	•	•	•	•	•	•	•	•	•	•	•	•	•	•	•	•	•	•	
			600	•	•	•	•	•	•	•	•	•	•	•	•	•	•	•	•	•	•	•	•	•	•	•	•	•	
	SPECIALS	Angle Globe Valves	150	•	•	•	•	•	•	•	•	•	•	•	•	•	•	•	•	•	•	•	•	•	•	•	•	•	
			300	•	•	•	•	•	•	•	•	•	•	•	•	•	•	•	•	•	•	•	•	•	•	•	•	•	
		Soft-seated Gate Valves	150	•	•	•	•	•	•	•	•	•	•	•	•	•	•	•	•	•	•	•	•	•	•	•	•	•	
			300	•	•	•	•	•	•	•	•	•	•	•	•	•	•	•	•	•	•	•	•	•	•	•	•	•	
			600	•	•	•	•	•	•	•	•	•	•	•	•	•	•	•	•	•	•	•	•	•	•	•	•	•	
		Live Loaded Gate / Globe Valves	150	•	•	•	•	•	•	•	•	•	•	•	•	•	•	•	•	•	•	•	•	•	•	•	•	•	
300	•		•	•	•	•	•	•	•	•	•	•	•	•	•	•	•	•	•	•	•	•	•	•	•	•			
600	•		•	•	•	•	•	•	•	•	•	•	•	•	•	•	•	•	•	•	•	•	•	•	•	•			
900	•		•	•	•	•	•	•	•	•	•	•	•	•	•	•	•	•	•	•	•	•	•	•	•	•			
API 6D Gate Valves	150-900	•	•	•	•	•	•	•	•	•	•	•	•	•	•	•	•	•	•	•	•	•	•	•	•	•	•		
	1500	•	•	•	•	•	•	•	•	•	•	•	•	•	•	•	•	•	•	•	•	•	•	•	•	•			

Common Test / Inspection methods

Test / Inspection	Method	Acceptance Criteria
Visual Inspection		MSS SP55
Chemical Analysis	ASTM E350	Relevant ASTM
Mechanical Properties	ASTM A370	Relevant ASTM
Radiographic Inspection	ASME B16.34	ASME B16.34
Magnetic Particle Inspection	ASTM E709	ASME B16.34
Liquid Penetrant Inspection	ASTM E165	ASME B16.34
Ultrasonic Inspection	ASTM A388	ASME B16.34
Positive Material Identification (PMI)	Vacuum emission spectrometer	Customer specification
Pressure Testing*	API 600/API 598/ BS 6755 Part I	API 600/API 598/ BS 6755 Part I
Dimensional Inspection		Valve Standard

L&T valves undergo a range of destructive and non-destructive tests according to the requirements of the Standard, service conditions and specific customer requirements.

* Performed on all valves.

The pressure containing parts of all valves are marked with the foundry identification and heat numbers.

Test Pressures for standard Carbon Steel Valves

Every individual valve manufactured, is inspected and pressure-tested to API 598 / BS 6755 Part I requirements, for which test certificates are provided.

ASME Class	Hydrostatic Test Pressure in kg/cm ² (psig)			Pneumatic low pressure closure test pressure in kg/cm ² (psig)
	Shell	Back Seat	Closure	
150	32 (450)	22 (315)	22 (315)	7 (100)
300	79 (1125)	57 (815)	57 (815)	7 (100)
600	156 (2225)	115 (1630)	115 (1630)	7 (100)
900	236 (3350)	172 (2445)	172 (2445)	7 (100)
1500	392 (5575)	287 (4080)	287 (4080)	7 (100)
2500	652 (9275)	477 (6790)	477 (6790)	7 (100)

Low Pressure Test for Swing Check Valves

In addition to the high pressure closure test, Swing Check Valves are subjected to low pressure hydrostatic closure test at a pressure of 25% of the high pressure closure test. The duration of the test is the same as that of the high pressure closure test.



Compliance Standards

Parameter	Compliance
API 600 Gate Valve	API 600
Globe Valve	BS 1873*
Check Valve	BS 1868*
API 603 Gate Valve	API 603
ASME B16.34 Gate, Globe, Check Valves	ASME B16.34
Pressure-Temperature rating	ASME B16.34
Face-to-face / End-to-end dimension	ASME B16.10
End Flange dimensions	ASME B16.5**
Butt-weld End dimensions	ASME B16.25
Valve Inspection & Testing	API 600, API 598, BS 6755 Part I

The valves also comply with applicable BS specifications.

* Shell wall thickness as per API 600

** For valves larger than 24" (600mm), the flange drilling shall be as per ASME B16.47 Series A (MSS SP 44) or Series B (API 605).

RTJ flanges are offered as optional for Class 600 and above.

Body / Bonnet Materials

L&T Valves Cast Steel Gate, Globe and Check Valves are offered in a variety of body and bonnet materials to suit different requirements. These materials include Carbon Steel (standard), Alloy Steels and Stainless Steels. For other materials of construction, refer to L&T Valves.

Material Classification	ASTM Specification	Working temperature*
Carbon Steel	ASTM A216 Gr. WCB	-29°C to 427°C (-20°F to 800°F)
1/4 Cr - 1/2 Mo	ASTM A217 Gr. WC6	-29°C to 593°C (-20°F to 1100°F)
2/4 Cr - 1 Mo	ASTM A217 Gr. WC9	-29°C to 593°C (-20°F to 1100°F)
5 Cr - 1/2 Mo	ASTM A217 Gr. C5	-29°C to 649°C (-20°F to 1200°F)
9 Cr - 1 Mo	ASTM A217 Gr. C12	-29°C to 649°C (-20°F to 1200°F)
9 Cr - 1 Mo - 1/4 V	ASTM A217 Gr. C12A	-29°C to 649°C (-20°F to 1200°F)
Low-temperature Steel	ASTM A352 Gr. LCB/LCC	-46°C to 343°C (-50°F to 650°F)
Austenitic Stainless Steel 18-8 (Type 304)	ASTM A351 Gr. CF8	-196°C to 649°C (-320°F to 1200°F)
Austenitic Stainless Steel 16Cr - 12Ni - 2 Mo (Type 316)	ASTM A351 Gr. CF8M	-196°C to 649°C (-320°F to 1200°F)

* ASME pressure-temperature ratings on pages 26 & 27. Bolting & trim materials will influence the working temperature.

Other materials such as ASTM A351 Gr. CF3, ASTM A351 Gr. CF3M and Duplex SS are also offered.

L&T Valves has the distinction of having obtained a number of national and international approvals. Notable among these are:

- **ISO 9001:2008 certified Quality Management System**
- **Certified to use "CE" marking for supply to the European Union**
- **Specific company approvals from national and international oil majors and EPC contractors**
- **Indian Boiler Regulation (IBR) certification for all three plants.**



L&T Gate, Globe & Check Valves

Bolted Bonnet / Cover design

The API 600 / BS 1873 / BS 1868 family of L&T Gate, Globe and Swing Check Valves is exceptionally sturdy, rugged and durable, with a reputation for quality, integrity and long service. They are designed for tight sealing and ease of operation. The valves are available with flanged ends or butt-weld ends, in pressure ratings from ASME Class 150 to Class 1500, and in a variety of materials of construction.

Gate Valves are of flexible wedge, outside screw-and-yoke and bolted-bonnet construction. The valves conform to API 600.

Globe Valves feature a ball-type disc, outside screw-and-yoke and bolted-bonnet construction. They conform to BS 1873 and also meet the general requirements of API 600, including shell wall thickness and stuffing box dimensions.

Check Valves are of swing-type and bolted-cover construction. They conform to BS 1868 and also meet the general requirements of API 600, including shell wall thickness.

Body and Bonnet

The body and bonnet are cast with uniform section and generous radius fillets to prevent stress concentration. The castings are precision-machined for high performance.

The gate valve body has a straight through port without recesses except at the seat area. This ensures minimum turbulence, erosion and resistance to flow. Long integral guide ribs in the body match with guide slots in the wedge for accurate alignment and guidance. Bonnet castings are of one-piece design, where the yoke is integral with the bonnet for gate valves of sizes up to 12" (300mm). This ensures accurate alignment of stem and a smooth operation.



In globe valves of larger sizes and for higher pressure classes of ASME Class 900 and above, the internal part of the body is machined to provide continuous guiding of the disc from the open to the closed position.



The check valve body provides a full port without pockets from inlet to the valve seat. On the downstream side, the body has generous proportions to facilitate full swing of the disc to reduce disc erosion and flow resistance.



Body-Bonnet Joint

The body-bonnet joint for Class 150 gate valves is oval in shape, while for Class 300 and for globe valves, this joint is circular in shape. In 2" (50mm) valves, the body-bonnet joint has a square configuration.

Gate valves of Class 150 rating have a flat-face joint with a graphite gasket having metallic inserts. Those of Class 300 rating have a male-female type joint with a spirally-wound gasket. Gate valves of Class 600 rating and above have a Ring Type Joint (RTJ).

Globe and Check valves in Class 150 and 300 ratings have a male-female type joint with a spirally-wound gasket. Those of Class 600 rating and above have an RTJ.

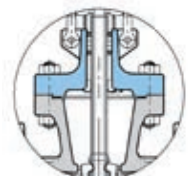

Square Joint

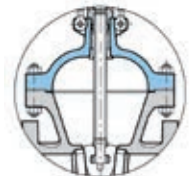

Circular Joint

Back Seat

In L&T gate and globe valves, a precision-machined back-seat bush is threaded in the bonnet and is secured by a tab-weld.

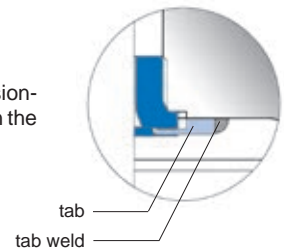

Flexible Wedge

L&T gate valves feature a one-piece cast flexible wedge that minimises stress concentration. Wedge flexibility ensures tight seating over a wide range of differential pressures and temperatures. It also adjusts to slight misalignments caused by pipeline deflections and thermal deformation. The stem-to-wedge thrust is applied close to the wedge centre. This reduces lateral stem loading and provides for more accurate wedge movement.

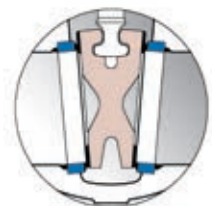

Ball-type Disc

L&T globe valves feature a ball-type disc that provides a fine grain surface on the taper seat. For severe services that demand hard-faced seats, a plug-type disc is provided.

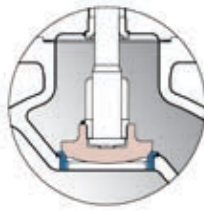

Swing-type Disc Assembly

The one-piece construction is securely fastened to the hinge by means of a lock nut and pin. The disc is free to rotate to avoid localized wear. The hinge pin offers excellent wear resistance properties.



Seat Ring

L&T gate valves and check valves feature a seal-welded seat ring that offers a leakproof design as it eliminates the leakage path between the seat ring and the body. This design is superior to threaded seats which can loosen up due to temperature fluctuations, corrosion or vibration and result in leakage. Threaded seat rings are optional. For 50mm gate valves, the seat ring is flared into the body, while seal welding is optional.

L&T globe valves feature a shoulder type, threaded body seat ring which has a wide taper area that provides for ample seating. Slots on the seat ring allow easy in-situ removal for servicing. Threaded seat rings are additionally secured by a tab-weld. Welded seat rings are also available in L&T Globe Valves.

Stem

L&T gate and globe valves feature a stem of one-piece construction, ACME threaded and precision-machined with polished surfaces to reduce friction, minimise leakage and extend stem life.

In gate valves, the heavy forged T-head engages with the T-slot in the wedge. The stem also has an integral self-adjusting radial back-seat shoulder that matches with the back-seat bush in the bonnet.

In globe valves, the stem is held to the disc by a stem nut that permits the disc to swivel. This free-floating design ensures uniform seating.



Yoke Sleeve and Yoke Bush

Cast in austenitic, copper-free ductile iron alloy to provide resistance to heat, corrosion and wear, the Yoke Sleeve in gate valves features a long thread engagement that assures accurate alignment of the stem. Moreover, it can be removed without replacing the bonnet. In gate valves of sizes 150mm and higher in Class 600 rating and above, the yoke sleeve is mounted on thrust bearings to facilitate easy operation.

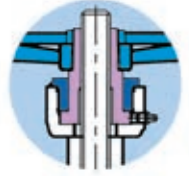

The Yoke Bush of globe valves is also made from ductile iron alloy, and has a long thread engagement for accurate stem alignment. In Class 900 and 1500 ratings, the valves have a yoke sleeve to facilitate smooth operation.

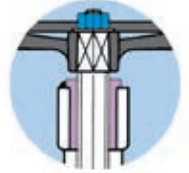

Stuffing Box

The machined stuffing box chamber with a flat bottom allows correct sealing of the gland packing. Surface finish is controlled to required limits, to ensure low-emission performance. Stuffing boxes are provided with five numbers of gland packing to achieve correct compression of all packings and to ensure tight sealing.

Valves in Class 300 rating and above feature a provision for a lantern ring arrangement for conditions that demand that there be no leakage of service fluid to the atmosphere. The lantern ring has a leakoff plug which allows connection for liquid or grease seal. See page 30 for more details on the lantern ring.

Flange Drilling and Facing finish

The standard range of L&T flanged valves in sizes of up to 24" (600mm) is finished with end-flanges faced, drilled and spot-faced (or backfaced) to ASME B16.5 Raised Face (RF). Flanges in valves of sizes larger than 24" (600mm) are drilled as per ASME B16.47 Series A (MSS SP 44) or Series B (API 605). Valves in ASME Class 600 and above are offered with RTJ end flanges on request.

The standard finish offered on the raised faces is 125-250 microns in Ra (AARRH) Spiral Serration. Other finishes can be offered on request.



Bonnet Gaskets

Valve Type	ASME Class	Typical	Optional
Gate	150	Graphite Gasket with SS 316 insert	Spirally-wound SS 304 / SS 316 with Graphite or PTFE filler
	300	Spirally-wound SS 304 with Graphite filler	Spirally-wound SS 316 with Graphite filler
	600	Spirally-wound SS 304 with Graphite filler	Spirally-wound SS 304 / SS 316 with PTFE filler
	900	Octagonal Ring Type (RTJ) metal gasket in Soft Iron	Octagonal Ring Type (RTJ) metal gasket in SS 304 / SS 316
	1500	Octagonal Ring Type (RTJ) metal gasket in Soft Iron	Octagonal Ring Type (RTJ) metal gasket in SS 304 / SS 316
Globe	150	Spirally-wound SS 304 with Graphite filler	Spirally-wound SS 316 with Graphite filler
	300	Spirally-wound SS 304 with Graphite filler	Spirally-wound SS 304 / SS 316 with PTFE filler
	600	Spirally-wound SS 304 with Graphite filler	Octagonal Ring Type (RTJ) metal gasket in Soft Iron
	900	Octagonal Ring Type (RTJ) metal gasket in Soft Iron	Octagonal Ring Type (RTJ) metal gasket in SS 304 / SS 316
Check	150	Spirally-wound SS 304 with Graphite filler	Octagonal Ring Type (RTJ) metal gasket in SS 304 / SS 316
	300	Spirally-wound SS 304 with Graphite filler	Octagonal Ring Type (RTJ) metal gasket in SS 304 / SS 316
	600	Spirally-wound SS 304 with Graphite filler	Octagonal Ring Type (RTJ) metal gasket in Soft Iron
	900	Octagonal Ring Type (RTJ) metal gasket in Soft Iron	Octagonal Ring Type (RTJ) metal gasket in SS 304 / SS 316
	1500	Octagonal Ring Type (RTJ) metal gasket in Soft Iron	Octagonal Ring Type (RTJ) metal gasket in SS 304 / SS 316

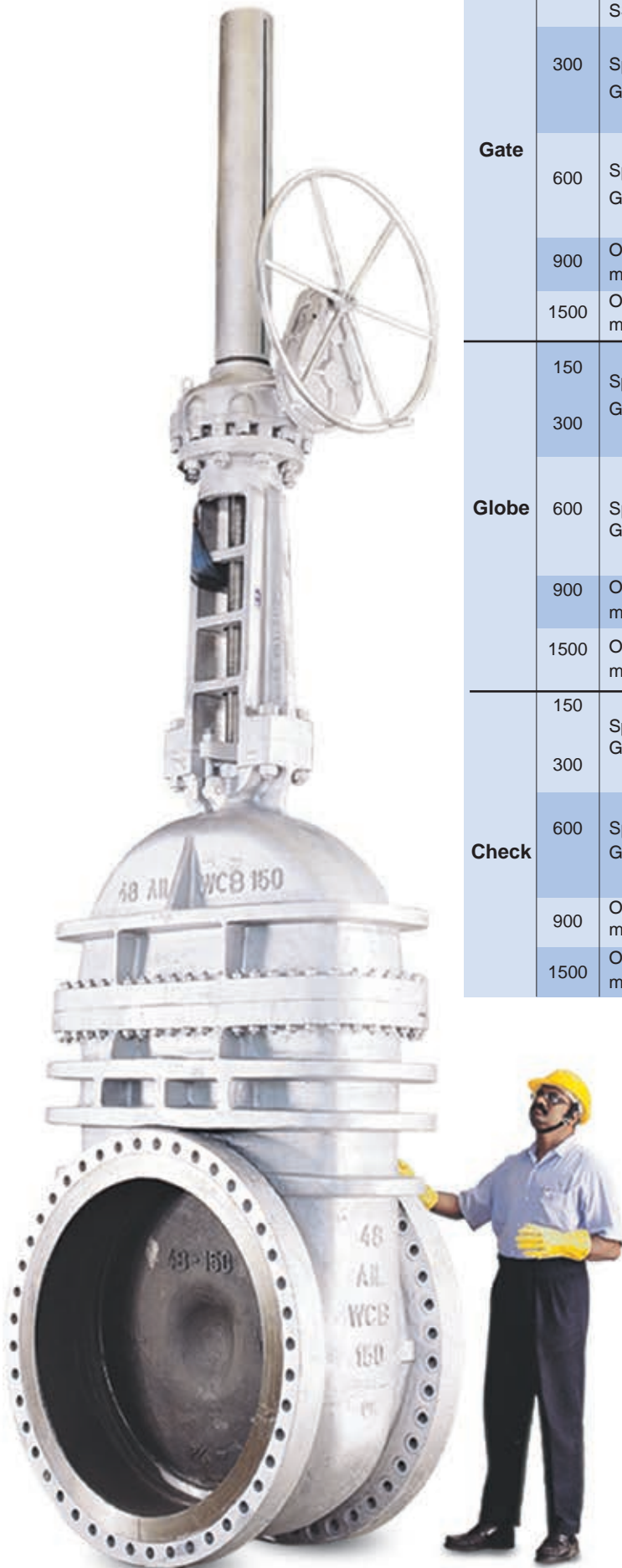

48-inch Class 150 Gate Valve

Ordering Information

Valve Size mm (in)	Valve Type	ASME Pr. Class	End Connection	Trim Number
50 (2")	1 Gate	1 Class 150	3 Flanged RF	1
65 (2 1/2")	4 Globe	3 Class 300	5 Flanged RTJ	2
80 (3")	7 Check	6 Class 600	6 Butt-weld	5
100 (4")		9 Class 900		8 <i>Refer table below on Trim Materials</i>
125 (5")		A Class 1500		9
150 (6")				10
200 (8")				12
250 (10")				16
300 (12")				
350 (14")				
400 (16")				
450 (18")				
500 (20")				
600 (24")				
700 (28")				
750 (30")				
850 (34")				
900 (36")				
1050 (42")				
1200 (48")				
1500 (60")				
1600 (64")				

As a standard, L&T Valves are made in Carbon Steel to ASTM A216 Gr. WCB. For valves in other materials and for accessories like gear operation and electrical actuators, suffix suitable abbreviations to the above ordering code such as:

WC6 for ASTM A217 Gr. WC6	GO for Gear Operation
WC9 for ASTM A217 Gr. WC9	LA for Locking Arrangement
LCB for ASTM A352 Gr. LCB	E for Electrical Actuator
LCC for ASTM A352 Gr. LCC	EB for Extended Bonnet (Cryogenic valves)
C5 for ASTM A217 Gr. C5	ES for Extension Spindle
C12 for ASTM A217 Gr. C12	IBR for IBR Certification
	FSJ for Full Steam Jacket
	PSJ for Partial Steam Jacket

Trim Materials

L&T Trim #	API 600 Trim #	Material of Construction			
		Stem	Seat Surface	Wedge / Disc Seating Surface	Back Seat
5	5	13% Cr.	HF*	HF*	13% Cr.
8	8	13% Cr.	HF*	13% Cr.	13% Cr.
9	9	Monel	Monel	Monel	Monel
12	12	SS 316	HF*	SS 316	SS 316
16	16	SS 316	HF*	HF*	SS 316@

@L&T Trim No. 16 will feature a back-seat of either SS 316 or SS 316 + HF*

* HF : Hard-faced with Stellite #6 (Co-Cr-W alloy) or equivalent.

Trim 12 valves comply with NACE MR 01 75 for hardness and heat treatment requirements of wetted components.

Trim 8 valves can also be offered for NACE service on request.

Stem Packing

Construction	Max. temp.
Die-formed flexible Graphite rings with braided Graphite top & bottom rings*	649°C (1200°F)
Braided PTFE	204°C (400°F)

* L&T standard

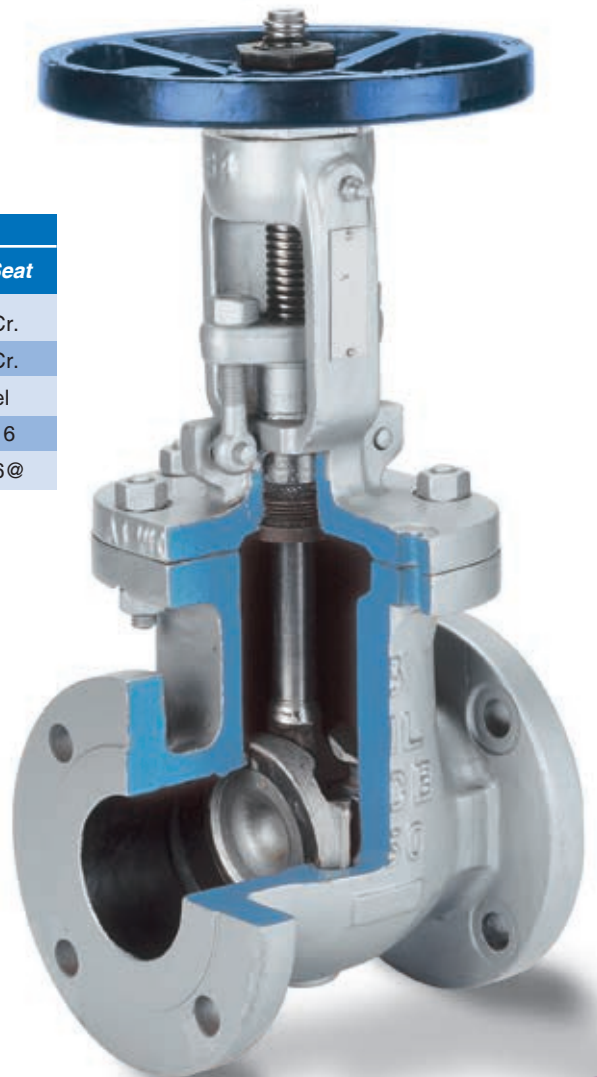

Gate Valves - ASME Classes 150, 300 & 600

Figure Numbers 113-8, 133-8 & 163-8

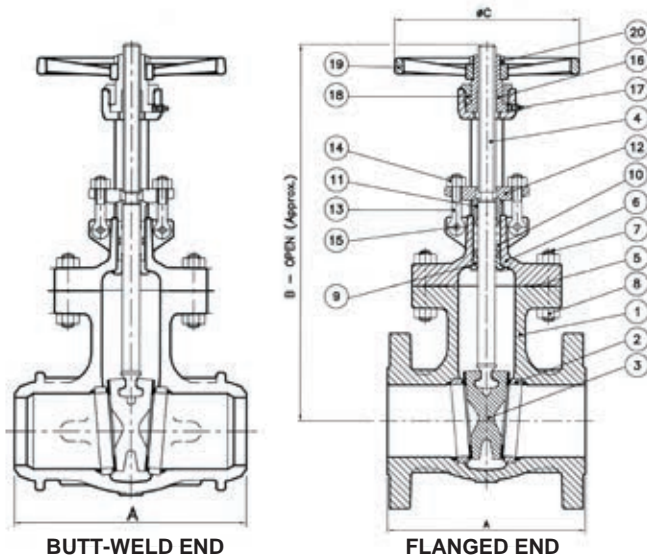

FOR 2" CL. 150, CL. 300 & CL. 600 FOR 3" & ABOVE CL. 300 FOR 3" & ABOVE CL. 600

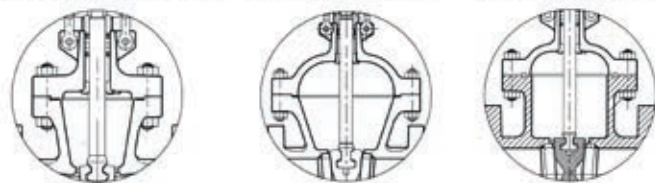

Standard Materials of Construction

Sl. No.	Description	Material
01	Body	ASTM A216 Gr. WCB
02	Body Seat Ring	ASTM A105 + HF*
03	Wedge	ASTM A216 Gr. WCB + 13% Cr. Steel
04	Stem	ASTM A182 Gr. F6a
05	Gasket - Cl.150	ASTM A308
	Gasket - Cl.300 & 600	Spirally-wound SS 304 with graphite filler
06	Bonnet	ASTM A216 Gr. WCB
07	Stud	ASTM A193 Gr. B7
08	Stud Nut	ASTM A194 Gr. 2H
09	Back-seat Bush	13% Cr. Steel
10	Packing	Graphite with braided end rings
11	Gland	Steel
12	Gland Flange	ASTM A105 / ASTM A216 Gr. WCB
13	Eye Bolt	Cr. - Mo Steel
14	Eye Bolt Nut	ASTM A194 Gr. 2H
15	Groove Pin	Steel
16	Yoke Sleeve (Stem Nut)	ASTM A439 Type D2
17	Grease Fitting	Steel
18	Retainer Nut	Steel / Ductile Iron / Malleable Iron
19	Handwheel	Steel / Ductile Iron / Malleable Iron
20	Handwheel Nut	Steel / Ductile Iron / Malleable Iron
	Nameplate	SS 304

* HF - Hard-Faced with Stellite #6 or equivalent
For other body / bonnet materials, refer page 5

Dimensions (in mm, unless specified) & Weights (in kg)

Valve Size	Class 150						Class 300						Class 600					
	A		B	C	Approx. Wt.		A		B	C	Approx. Wt.		A		B	C	Approx. Wt.	
	Fl.	B/W			Fl.	B/W	Fl.	B/W			Fl.	B/W	Fl.	B/W			Fl.	B/W
50 (2")	178	216	376	203	21	19	216	216	399	203	25	23	292	292	399	203	42	36
65 (2 1/2")	191	241	480	229	32	27	241	241	505	229	48	34	-	-	-	-	-	-
80 (3")	203	283	480	229	35	27	283	283	505	229	53	41	356	356	541	254	67	63
100 (4")	229	305	584	254	53	43	305	305	604	254	78	55	432	432	635	305	119	112
125 (5")	254	381	750	254	75	64	381	381	850	356	135	105	-	-	-	-	-	-
150 (6")	267	403	790	305	87	77	403	403	850	356	158	111	559	559	874	457	252	225
200 (8")	292	419	996	356	139	118	419	419	1039	406	234	186	660	660	1044	457	418	365
250 (10")	330	457	1205	406	210	198	457	457	1265	457	355	284	787	787	1285	508	652	554
300 (12")	356	502	1410	457	302	271	502	502	1460	508	495	400	838	838	1476	610	1100	984
350 (14")	381	572	1539	508	410	365	762	762	1590	508	750	620	889	889	1565	610	1600	1465
400 (16")	406	610	1752	508	520	490	838	838	1791	610	958	850	991	991	2062	762	1955	1760
450 (18")	432	660	1956	610	690	665	914	914	2126	686	1310	1075	1092	1092	2062	762	2075	1840
500 (20")	457	711	2159	610	900	865	991	991	2261	686	1640	1525	1194	1194	3048	762	2150	1960
600 (24")	508	813	2565	686	1410	1375	1143	1143	2654	762	2460	2075	1397	1397	3150	762	3620	3180
700 (28")	610	991	3160	762	2060	1750	-	-	-	-	-	-	-	-	-	-	-	-
750 (30")	610	914	3429	762	3100	2850	1397	1397	4267	1016	4750	-	-	-	-	-	-	-
850 (34")	711	-	3650	762	3350	2950	-	-	-	-	-	-	-	-	-	-	-	-
900 (36")	711	-	3734	762	3980	3000	1727	-	3975	-	-	-	-	-	-	-	-	-
1050 (42")	813	1118	4200	-	*	4500	-	-	-	-	-	-	2438	-	4420	-	-	-
1200 (48")	864	1118	4990	-	*	6000	-	-	-	-	-	-	-	-	-	-	-	-
1500 (60")	1143	-	6175	-	*	-	-	-	-	-	-	-	-	-	-	-	-	-

Fl. - Flanged ; B/W - Butt-weld. * Depends on flange dimensions. Intermediate sizes 22", 26", 32", 38", 40", 44", 46" in Class 150 are also offered.

Class 600 gate valves can also be given in pressure seal bonnet design, in sizes from 80mm (3") up to 300mm (12"). For details of pressure seal bonnet arrangement, see page 18.

Gate Valves - ASME Classes 900 & 1500

Figure Numbers 193-8 & 1A3-8

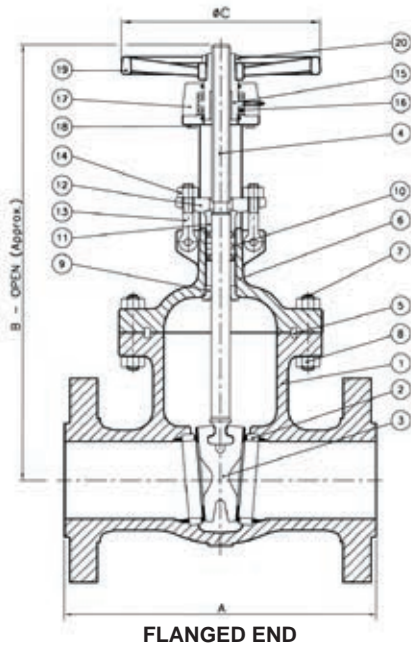

FLANGED END

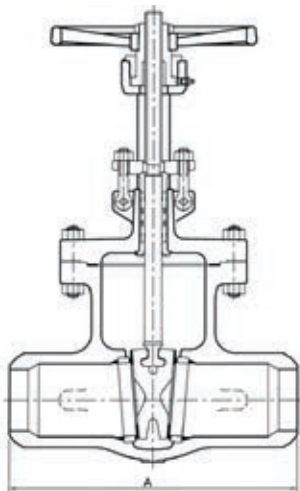

BUTT-WELD END

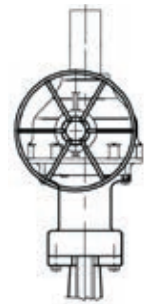

GEAR UNIT ASSEMBLY



Standard Materials of Construction

Sl. No.	Description	Material
01	Body	ASTM A216 Gr. WCB
02	Body Seat Ring	ASTM A105 + HF*
03	Wedge	ASTM A216 Gr. WCB + 13% Cr. Steel
04	Stem	ASTM A182 Gr. F6a
05	Gasket RTJ	Soft Iron
06	Bonnet	ASTM A216 Gr. WCB
07	Stud	ASTM A193 Gr. B7
08	Stud Nut	ASTM A194 Gr. 2H
09	Back-seat Bush	13% Cr. Steel
10	Packing	Graphite with braided end rings
11	Gland	13% Cr. Steel
12	Gland Flange	ASTM A105 / ASTM A216 Gr. WCB
13	Eye Bolt	13% Cr. Steel
14	Eye Bolt Nut	ASTM A194 Gr. 2H
15	Yoke Sleeve (Stem Nut)	ASTM A439 Type D2
16	Bearing	Steel
17	Yoke Cap	Ductile Iron
18	Screw	Steel
19	Handwheel	Steel / Ductile Iron /
20	Handwheel Nut	Malleable Iron
	Nameplate	SS 304

* HF - Hard-Faced with Stellite #6 or equivalent
For other body / bonnet materials, refer page 5

Dimensions (in mm, unless specified) & Weights (in kg)

Valve Size	Class 900						Class 1500					
	A		B	C	Approx. Wt.		A		B	C	Approx. Wt.	
	Fl.	B/W			Fl.	B/W	Fl.	B/W			Fl.	B/W
50 (2")	-	-	-	-	-	-	368	368	570	229	128	115
80 (3")	381	381	700	305	138	126	470	470	720	305	255	245
100 (4")	457	457	800	356	216	196	546	546	850	356	315	285
150 (6")	610	610	1100	508	426	375	705	705	1200	508	643	570
200 (8")	737	737	1500	508	723	625	832	832	1600	508	1258	1120
250 (10")	838	838	1800	762	1173	1040	991	991	1950	762	2008	1760
300 (12")	965	965	2000	762	1792	1610	1130	1130	2150	762	2963	2580
400 (16")	1130	-	2000	762	2535	-	-	-	-	-	-	-

Fl. - Flanged ; B/W - Butt-weld.

Sizes 18", 20" and 24" are also offered.

Globe Valves - ASME Class 150, 300 & 600

Figure Numbers 413-8, 433-8 & 463-8

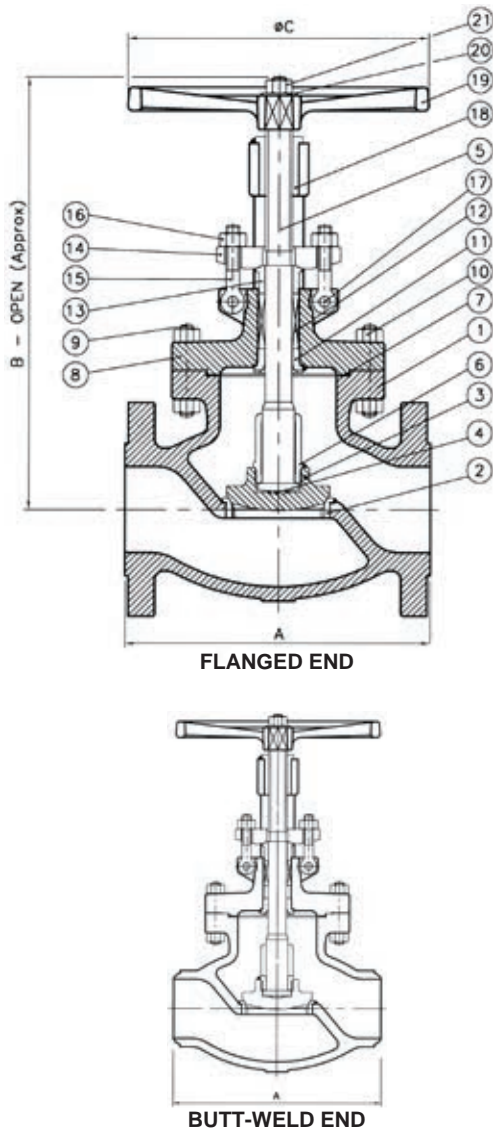

Standard Materials of Construction

Sl. No.	Description	Material
01	Body	ASTM A216 Gr. WCB
02	Body Seat Ring	ASTM A182 Gr. F6a+HF
03	Disc	ASTM A216 Gr. WCB + 13% Cr. Steel
04	Disc Washer	13% Cr. Steel
05	Stem	ASTM A182 Gr. F6a
06	Disc Stem Nut	13% Cr. Steel
07	Gasket	ASTM A308
08	Bonnet	ASTM A216 Gr. WCB
09	Stud	ASTM A193 Gr. B7
10	Stud Nut	ASTM A194 Gr. 2H
11	Back-seat Bush	13% Cr. Steel
12	Packing	Graphite with braided end rings
13	Gland	13% Cr. Steel
14	Gland Flange	ASTM A105 / ASTM A216 Gr. WCB
15	Eye Bolt	Cr. - Mo Steel
16	Eye Bolt Nut	ASTM A194 Gr. 2H
17	Groove Pin	Steel
18	Yoke Bush	ASTM A439 Type D2
19	Handwheel	Steel / Ductile Iron / Malleable Iron
20	Washer	Steel
21	Handwheel Nut	ASTM A563 Gr. B
	Nameplate	SS 304

* HF - Hard-Faced with Stellite #6 or equivalent
For other body / bonnet materials, refer page 5

Dimensions (in mm, unless specified) & Weights (in kg)

Valve Size	Class 150						Class 300						Class 600					
	A		B	C	Approx. Wt.		A		B	C	Approx. Wt.		A		B	C	Approx. Wt.	
	Fl.	B/W			Fl.	B/W	Fl.	B/W			Fl.	B/W	Fl.	B/W			Fl.	B/W
50 (2")	203	203	335	203	23	20	267	267	355	203	33	28	292	292	400	254	42	38
65 (2 1/2")	216	-	355	203	35	-	292	-	410	203	46	-	-	-	-	-	-	-
80 (3")	242	242	421	254	41	38	317	317	457	254	58	50	356	356	560	356	75	60
100 (4")	292	292	477	254	66	62	356	356	556	356	97	84	432	432	593	406	136	116
150 (6")	406	406	575	356	118	110	445	445	668	457	186	164	559	559	837	610	245	195
200 (8")	495	495	680	457	207	195	559	559	830	610	329	296	661	661	947	610	546	466
250 (10")	623	623	895	356	335	320	623	623	1206	610	520	471	787	787	1285	762	756	656
300 (12")	699	699	1215	610	495	470	711	711	1160	762	705	634	838	838	1560	762	1086	896

Fl. - Flanged ; B/W - Butt-weld.

Globe Valves - ASME Class 900 & 1500

Figure Numbers 493-8 & 4A3-8

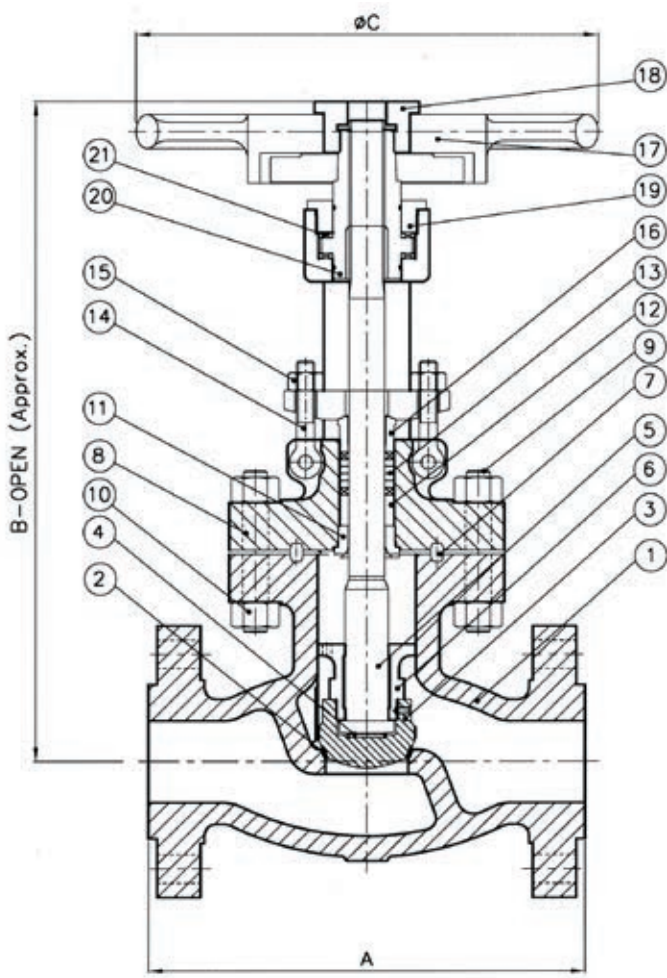

FLANGED END

Standard Materials of Construction

Sl. No.	Description	Material
01	Body	ASTM A216 Gr. WCB
02	Body Seat	Integral Stellite #6 or eq.
03	Disc	ASTM A216 Gr. WCB + 13% Cr. Steel
04	Disc Washer	13% Cr. Steel
05	Stem	ASTM A182 Gr. F6a
06	Disc Stem Nut	13% Cr. Steel
07	Gasket RTJ	SS 316
08	Bonnet	ASTM A216 Gr. WCB
09	Stud	ASTM A193 Gr. B7
10	Stud Nut	ASTM A194 Gr. 2H
11	Back-seat Bush	13% Cr. Steel
12	Spacer	13% Cr. Steel
13	Packing	Graphite with braided end rings
14	Eye Bolt	ASTM A193 Gr. B7
15	Eye Bolt Nut	ASTM A194 Gr. 2H
16	Gland	13% Cr. Steel
17	Handwheel	Steel / Ductile Iron / Malleable Iron
18	Handwheel Nut	Malleable Iron
19	Retainer Nut	
20	Yoke Sleeve	ASTM A439 Type D2
21	Bearing	Steel
	Nameplate	SS 304

* HF - Hard-Faced with Stellite #6 or equivalent
For other body / bonnet materials, refer page 5

Dimensions (in mm, unless specified) & Weights (in kg)

Valve Size	Class 900						Class 1500					
	A		B	C	Approx. Wt.		A		B	C	Approx. Wt.	
	Fl.	B/W			Fl.	B/W	Fl.	B/W			Fl.	B/W
50 (2")	-	-	-	-	-	-	368	368	590	305	110	85
80 (3")	381	381	700	305	138	120	470	470	720	305	255	195
100 (4")	457	467	800	356	216	180	546	546	850	356	315	265
150 (6")	610	610	1100	508	426	395	-	-	-	-	-	-

Fl. - Flanged ; B/W - Butt-weld.

Swing Check Valves - ASME Class 150, 300 & 600

Figure Numbers 713-8, 733-8 & 763-8

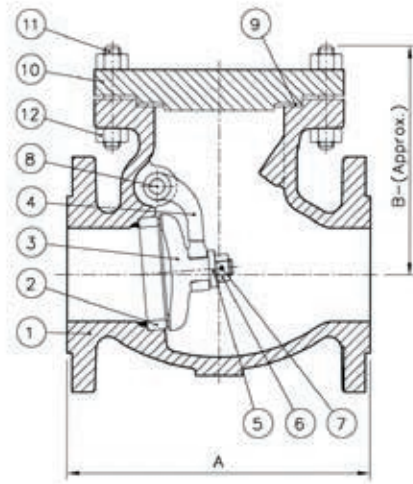

FLANGED END

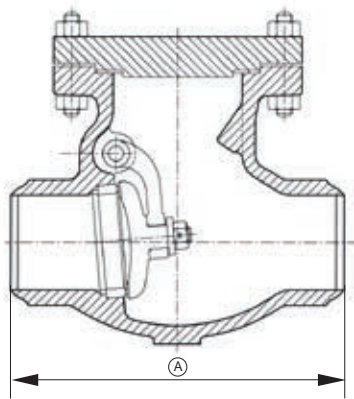

BUTT-WELD END



COVER FOR 3" VALVE (CLASS 600)

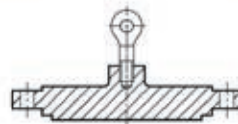

COVER & EYEBOLT ARRANGEMENT FOR 12" VALVE (CLASS 150)

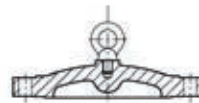

COVER & EYEBOLT ARRANGEMENT FOR VALVES 14" & ABOVE (CLASS 150), VALVES 10" & ABOVE (CLASS 300) & VALVES 4" & ABOVE (CLASS 600)

Standard Materials of Construction

Sl. No.	Description	Material
01	Body	ASTM A216 Gr. WCB
02	Body Seat Ring	ASTM A105 + HF*
03	Disc	ASTM A216 Gr. WCB + 13% Cr. Steel
04	Hinge	ASTM A216 Gr. WCB
05	Disc Washer	13% Cr. Steel
06	Disc Nut	SS 304
07	Disc Nut Pin	13% Cr. Steel
08	Hinge Pin	13% Cr. Steel
09	Gasket	ASTM A308
10	Cover	ASTM A216 Gr. WCB
11	Stud	ASTM A193 Gr. B7
12	Stud Nut	ASTM A194 Gr. 2H
	Hinge Pin Cover	ASTM A105
	Hinge Pin Cover Bolt	ASTM A193 Gr. B7
	Nameplate	SS 304

* HF - Hard-Faced with Stellite #6 or equivalent
For other body / cover materials, refer page 5

Dimensions (in mm, unless specified) & Weights (in kg)

Valve Size	Class 150					Class 300					Class 600				
	A		B	Approx. Wt.		A		B	Approx. Wt.		A		B	Approx. Wt.	
	Fl.	B/W		Fl.	B/W	Fl.	B/W		Fl.	B/W	Fl.	B/W		Fl.	B/W
50 (2")	203	203	165	21	19	267	267	165	24	19	292	292	178	35	30
65 (2 1/2")	216	216	175	24	20	-	-	-	-	-	-	-	-	-	-
80 (3")	241	241	181	34	30	317	317	190	45	36	356	356	203	55	46
100 (4")	292	292	213	49	42	356	356	229	70	56	432	432	229	92	70
150 (6")	356	356	273	88	79	444	444	279	151	129	559	559	365	204	161
200 (8")	495	495	335	168	154	533	533	343	242	210	661	661	442	323	260
250 (10")	622	622	406	280	260	622	622	368	333	284	787	787	450	550	455
300 (12")	698	698	483	413	382	711	711	412	450	378	838	838	590	790	680
350 (14")	788	788	515	509	466	839	839	559	659	556	-	-	-	-	-
400 (16")	864	864	455	580	524	864	864	636	873	747	-	-	-	-	-
450 (18")	978	978	500	635	583	978	978	562	1090	900	-	-	-	-	-
500 (20")	978	978	675	925	855	1016	1016	675	1360	1176	-	-	-	-	-
600 (24")	1295	1295	780	1500	1403	1346	1346	790	1850	1573	-	-	-	-	-

Fl. - Flanged ; B/W - Butt-weld.

Swing Check Valves - ASME Class 900 & 1500

Figure Numbers 793-8 & 7A3-8

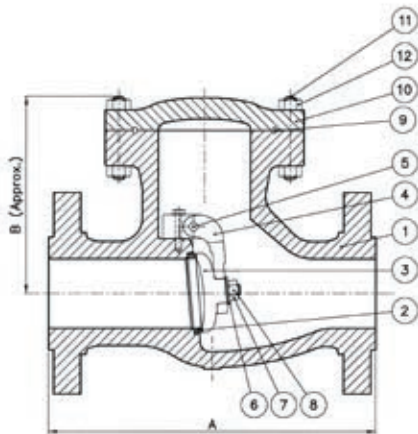

FLANGED END

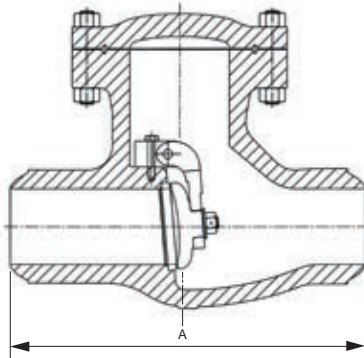

BUTT-WELD END

Standard Materials of Construction

Sl. No.	Description	Material
01	Body	ASTM A216 Gr. WCB
02	Body Seat Ring	ASTM A105 + HF*
03	Disc	ASTM A216 Gr. WCB + 13% Cr. Steel
04	Hinge	ASTM A216 Gr. WCB
05	Hinge Pin	13% Cr. Steel
06	Disc Washer	13% Cr. Steel
07	Disc Nut	SS 304
08	Disc Nut Pin	SS 304
09	Gasket RTJ	Soft Iron
10	Cover	ASTM A216 Gr. WCB
11	Stud	ASTM A193 Gr. B7
12	Stud Nut	ASTM A194 Gr. 2H
	Nameplate	SS 304

* HF - Hard-Faced with Stellite #6 or equivalent
For other body / cover materials, refer page 5

Dimensions (in mm, unless specified) & Weights (in kg)

Valve Size	Class 900					Class 1500				
	A		B	Approx. Wt.		A		B	Approx. Wt.	
	Fl.	B/W		Fl.	B/W	Fl.	B/W		Fl.	B/W
50 (2")	-	-	-	-	-	368	368	250	69	53
65 (2½")	-	-	-	-	-	-	-	-	-	-
80 (3")	381	381	250	88	70	470	470	285	118	89
100 (4")	457	457	280	162	131	546	546	340	177	134
150 (6")	610	610	350	336	275	705	705	400	566	467
200 (8")	737	737	420	673	569	832	832	465	892	728
250 (10")	838	838	510	938	789	991	991	570	1730	1447
300 (12")	965	965	610	1480	1280	1130	1130	680	2580	2157

Fl. - Flanged ; B/W - Butt-weld



API 603 L&T Stainless Steel Gate Valves

Bolted Bonnet design

The API 603 family of L&T Stainless Steel Gate Valves is an economic alternative to API 600 Stainless Steel Gate Valves. They are available in flanged construction and in pressure ratings of ASME Class 150 and Class 300.

Gate Valves are of flexible wedge, outside screw-and-yoke and bolted-bonnet construction.



Body and Bonnet

The body and bonnet are cast with uniform section and generous radius fillets to prevent stress concentration. The castings are precision-machined for high performance.

The gate valve body has a straight through port without recesses except at the seat area. This ensures minimum turbulence, erosion and resistance to flow. Long integral guide ribs in the body match with full-length guide slots in the wedge for accurate alignment and guidance.

Flexible Wedge

The valves feature a one-piece cast flexible wedge that minimises stress concentration. Wedge flexibility ensures tight seating over a wide range of differential pressures and temperatures. It also adjusts to slight misalignments caused by pipeline deflections and thermal deformation. The stem-to-wedge thrust is applied close to the wedge centre. This reduces lateral stem loading and provides for more accurate wedge movement.

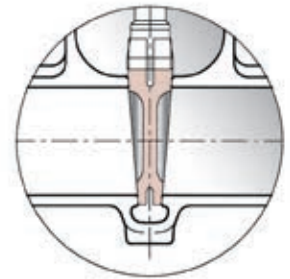

Ordering Information

Valve Size mm (in)	Valve Type	ASME Pr. Class	End Connection	Trim
50 (2") 80 (3") 100 (4") 150 (6") 200 (8") 250 (10") 300 (12")	3 Gate - API 603	1 Class 150 3 Class 300	3 Flanged RF	10 Refer table on 12 Trim Materials 16 on page 9

As a standard, API 603 Gate Valves are made of Stainless Steel ASTM A351 Grade CF8M. For accessories like gear operation and electrical actuators, suffix suitable abbreviations to the above ordering code such as:

- GO for Gear Operation
- LA for Locking Arrangement
- E for Electrical Actuator

Stainless Steel Gate Valves - ASME Class 150 & 300

Figure Numbers 313-10 & 333-10

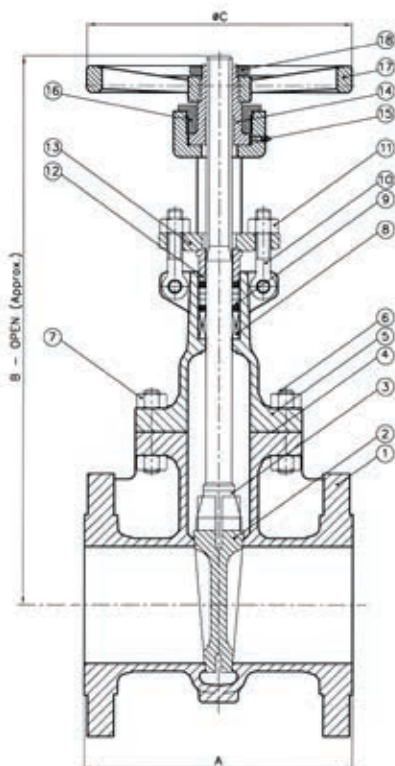

Standard Materials of Construction

Sl. No.	Description	Material
01	Body	ASTM A351 Gr. CF8M
02	Wedge	ASTM A351 Gr. CF8M
03	Stem	ASTM A182 Gr. F316
04	Gasket - Cl.150 Gasket - Cl.300	Graphite with SS 316 insert Spirally-wound SS 304 with graphite filler
05	Bonnet	ASTM A351 Gr. CF8M
06	Stud	ASTM A193 Gr. B8 Cl.2
07	Stud Nut	ASTM A194 Gr. 8
08	Spacer	SS 316
09	Packing	Graphite with braided end rings
10	Eye Bolt	SS 316
11	Eye Bolt Nut	ASTM A194 Gr. 8
12	Gland	SS 316
13	Gland Flange	SS 316
14	Yoke Sleeve (Stem Nut)	ASTM A439 Type D2
15	Grease Fitting	SS 304
16	Retainer Nut	SS 304
17	Handwheel	ASTM A536 Gr. 60-40-18 / ASTM A602 Gr. M3210
18	Handwheel Nut	SS 304
	Nameplate	SS 304

* HF - Hard-Faced with Stellite #6 or equivalent



Dimensions (in mm, unless specified) & Weights (in kg)

Valve Size	Class 150				Class 300			
	A	B	C	Approx. Wt.	A	B	C	Approx. Wt.
50 (2")	178	385	160	18	216	400	204	24
80 (3")	203	495	204	26	283	505	229	45
100 (4")	229	610	229	44	305	630	254	67
150 (6")	267	820	254	66	403	860	356	121
200 (8")	292	1025	305	110	419	1060	406	184
250 (10")	330	1250	356	158	457	1280	457	295
300 (12")	356	1655	406	225	502	1780	508	416

Fl. - Flanged ; B/W - Butt-weld



ASME B16.34 L&T Gate, Y-Globe & Swing Check Valves

Pressure Seal Bonnet design

The ASME B16.34 family of L&T Gate, Y-Globe and Swing Check Valves features a pressure seal bonnet design for high pressure services. These valves are extensively used in high pressure and high temperature steam, oil, gas, chemical and water applications in thermal power plants, fertiliser plants, petrochemical plants and refineries. The valves are available with butt-weld ends in pressure ratings of Classes 900, 1500 and 2500, and come in carbon steel and alloy steel construction.

Gate valves also meet the requirements of API 600 Style A.



GATE VALVES

Parallel Slide Disc Mechanism

This mechanism consists of two independent discs held by a disc carrier. An alloy steel spring between the discs provides the initial loading to keep the discs pressed against the body seats. The disc faces are parallel to each other and seal on parallel seat rings in the body. Sealing takes place by utilizing the line pressure to provide tight seal on the downstream seat. As the two discs are independent and parallel, opening / closing torques are significantly lower than comparable wedge disc designs, thereby minimizing the possibility of jamming at high temperatures or pressures.

When the valve is operated, the discs are allowed to slide and rotate over the body seats. This helps wipe out foreign particles from the seat faces.

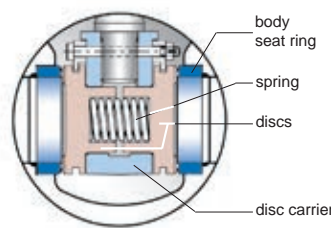

Pressure Seal arrangement for body-bonnet joint

This pressure seal body-bonnet joint utilizes the line pressure to create a tight body-bonnet seal. Sealing is achieved by compressing a high-purity graphite gasket between the bonnet and the body retainer ring. Preloaded fasteners provide an initial tight seal at low line pressures. At higher pressures, the line pressure pushes up the bonnet against the gasket, compressing it further and providing a much tighter seal.

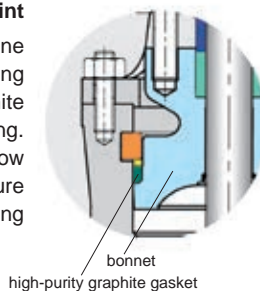

Trim

Both the disc and the seat ring faces are hard-faced with Stellite #6 or equivalent.

Stem and Gland Packing

The valves feature a stem, made of 13% Cr. Steel - ACME threaded, precision-machined and ground to a high finish to ensure a smooth operation. The high-purity graphite gland packings, used for stem sealing, provide capability to withstand high temperatures and pressures, and also to resist many chemicals. The smooth-finish stuffing box ensures longer life for the packings.

Yoke Sleeve and Thrust Bearings

The yoke sleeve is made of nodular Niresist Iron, supported by a set of bearings to reduce friction and the consequent torque required to operate the valves. Nodular Niresist Iron also withstands high temperatures. Weather seals, provided in the yoke sleeve, protect the bearing area against ingress of dirt and water.

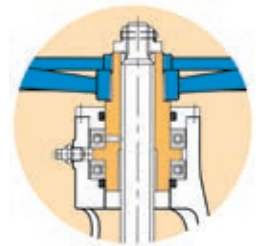

Seat Rings

Body seat rings are welded to the body to offer a leakproof design as they eliminate the leakage path between the seat ring and the body. This design is superior to screwed seats which can loosen up due to temperature fluctuations, corrosion or vibration and result in leakage.

Back-seat

The back-seat is in-situ hard-faced with Stellite #6 or equivalent.

Accessories

L&T Valves can be supplied with accessories such as bypass arrangement, drain plugs, live-loading and mountings like extension spindles, floor stands and chain wheel. The valves can also be supplied with gear units and electrical actuators.



Y-GLOBE VALVES

By virtue of their Y-type configuration, L&T Y-Globe Valves have a relatively straight flow and a lower pressure drop compared to conventional globe valves. The valves are suitable for tight shutoff and throttling in high pressure and high temperature lines.

Some of the unique features of L&T Y-Globe Valves are :

- Pressure Seal Bonnet
- Low operating torque due to use of thrust bearings
- Non-rotating stem
- Integrally-stellited body seats
- Fully-guided disc with Stellite seating and guiding surface
- Impactor handwheel in sizes of 6" (150mm) and above

SWING CHECK VALVES

L&T Swing Check Valves feature a pressure-seal body-cover joint and seal-welded seat rings. The seating surfaces are hard-faced with Stellite #6 or equivalent.

Swing-type Disc

The disc is of swing-type design and is opened by line velocity and the resultant pressure. When the flow stops, the disc is closed by gravity. Seating load and the resultant tightness are dependent on the back pressure.

As the disc is internally hinged, there is no opening in the body of the valve. This ensures high integrity.

Installation

L&T Swing Check Valves are used to prevent the reversal of flow in vertical, horizontal or inclined pipelines. These valves are to be used only for upward or horizontal flow. Pulsating flows, as obtained at the outlet of a reciprocating pump, would cause disc chatter and hence ought to be avoided.

End Connection

L&T Valves with butt-weld ends comply with ANSI B16.25 Fig. 2a or 3a, as applicable. For ANSI pipes, pipe schedule ought to be specified. For non-ANSI pipes, OD (or ID) and wall thickness ought to be furnished for end preparation.

Ordering Information

Valve Size mm (in)	Valve Type	ASME Pr. Class	End Connection	Trim	Disc
50 (2") 80 (3") 100 (4") 150 (6") 200 (8") 250 (10") 300 (12") 350 (14") 400 (16") 450 (18") 500 (20") 600 (24")	3 Pressure Seal Bonnet / Cap	Gate Valve 81 Class 900 86 Class 1500 91 Class 2500 Globe Valve 61 Class 900 66 Class 1500 71 Class 2500 Check Valve 80 Class 900 85 Class 1500 90 Class 2500	1/2 Butt-weld Flanged RF Flanged RTJ	U Hard-faced	P Gate Valve Parallel Slide Disc F Flexible Wedge TDCV Tilting Disc Check Valve
			WC6 for ASTM A217 Gr. WC6 WC9 for ASTM A217 Gr. WC9 C12A for ASTM A217 Gr. C12A	As a standard, L&T Valves are made in Carbon Steel to ASTM A216 Gr. WCB. For valves in other materials and for accessories like gear operation and electrical actuators, suffix suitable abbreviations to the above ordering code such as: GO for Gear Operation LA for Locking Arrangement ACT for Actuator BP for Bypass IBR for IBR-certified	

Pr. Seal Bonnet Gate Valves - ASME Class 900, 1500 & 2500

Figure Numbers 381^{1/2}UP, 386^{1/2}UP & 391^{1/2}UP

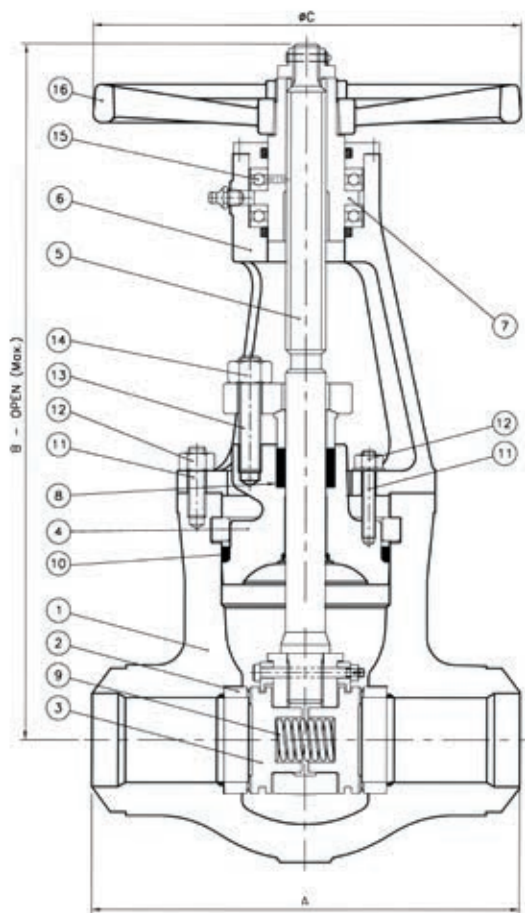

Standard Materials of Construction

Sl. No.	Description	Material		
01	Body	ASTM A216 Gr. WCB	ASTM A217 Gr. WC6	ASTM A217 Gr. WC9
02	Body Seat Ring	ASTM A216 Gr. WCB+HF*	ASTM A217 Gr. WC6+HF*	ASTM A217 Gr. WC9+HF*
03	Disc	ASTM A216 Gr. WCB+HF*	ASTM A217 Gr. WC6+HF*	ASTM A217 Gr. WC9+HF*
04	Bonnet	ASTM A216 Gr. WCB	ASTM A217 Gr. WC6	ASTM A217 Gr. WC9
05	Stem	13% Cr. Steel		
06	Yoke	ASTM A216 Gr. WCB		
07	Yoke Sleeve	ASTM A439 Type D2		
08	Packing	Graphite with braided end rings		
09	Spring	Inconel X750 / Nimonic 90		
10	Gasket	Graphite		
11	Stud	ASTM A193 Gr. B7		
12	Stud Nut	ASTM A194 Gr. 2H		
13	Gland Stud	ASTM A193 Gr. B7		
14	Gland Nut	ASTM A194 Gr. 2H		
15	Thrust Ball Bearing	Steel		
16	Handwheel	Steel / Malleable Iron / SG Iron		
	Nameplate	SS 304		

* HF - Hard-Faced with Stellite #6 or equivalent

Class 900 and Class 1500 gate valves can also be offered in flexible wedge design for the full range. For details of flexible wedge arrangement, refer Page 6.

Dimensions (in mm, unless specified) & Weights (in kg)

Valve Size	Class 900				Class 1500				Class 2500			
	A	B	C	Approx. Wt.	A	B	C	Approx. Wt.	A	B	C	Approx. Wt.
50 (2")	216	470	229	45	216	470	229	45	279	450	229	50
80 (3")	305	580	305	55	305	580	305	60	368	710	457	120
100 (4")	356	730	356	95	406	730	356	105	457	720	457	140
150 (6")	508	890	508	190	559	890	508	230	610	925	610	305
200 (8")	660	1040	686	350	711	1375	508	440	762	1370	762	685
250 (10")	787	1540	762	710	864	1540	762	850	914	1490	762	1270
300 (12")	914	1785	762	1000	991	1720	762	1045	1041	1690	762	1895
350 (14")	991	1825	762	1145	1067	1730	762	*	1118	1850	762	*
400 (16")	1092	2050	762	*	1194	2100	762	*	1245	2050	762	*
450 (18")	*	*	*	*	1346	2150	762	*	1397	2300	762	*
500 (20")	*	*	*	*	1473	2500	762	*	*	*	*	*
600 (24")	*	*	*	*	*	*	*	*	*	*	*	*

* Refer to L&T

2" valves are in flexible wedge design.

Valves in sizes of 10" and above in Class 900 and, 8" and above in Classes 1500 and 2500 are supplied with gear unit.

Pr. Seal Bonnet Y-Globe Valves - ASME Class 1500

Figure No. 366^{1/2}US

Standard Materials of Construction

Sl. No.	Description	Material		
01	Body	ASTM A216 Gr. WCB+HF*	ASTM A217 Gr. WC6+HF*	ASTM A217 Gr. WC9+HF*
02	Bonnet	ASTM A216 Gr. WCB	ASTM A217 Gr. WC6	ASTM A217 Gr. WC9
03	Disc	SS 410 Hard-Faced with Stellite #6 or equiv.		
04	Stem	ASTM A479 Type 410		
05	Packing	Graphite with braided end rings		
06	Yoke	ASTM A216 Gr. WCB		
07	Gasket	Graphite		
08	Stud	ASTM A193 Gr. B7		
09	Stud Nut	ASTM A194 Gr. 2H		
	Nameplate	SS 304		

* HF - Seat Hard-Faced with Stellite #6 or equivalent

Dimensions (in mm, unless specified)

Valve Size	Class 1500**		
	A	B	C
80 (3")	470	650	508
100 (4")	546	875	508
150 (6")	705	1210	762
200 (8")	832	2000	762

** Refer to L&T for dimensions of 10" and 12" sizes and of Class 2500 valves.

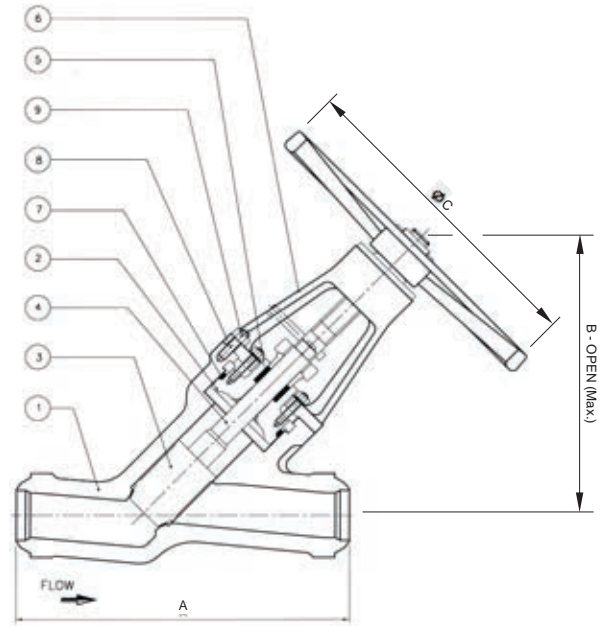

Pr. Seal Cover Swing Check Valves - ASME Class 900, 1500 & 2500

Figure Nos. 380^{1/2}U, 385^{1/2}U & 390^{1/2}U

Standard Materials of Construction

Sl. No.	Description	Material		
01	Body	ASTM A216 Gr. WCB	ASTM A217 Gr. WC6	ASTM A217 Gr. WC9
02	Cover	ASTM A216 Gr. WCB	ASTM A217 Gr. WC6	ASTM A217 Gr. WC9
03	Disc	ASTM A216 Gr. WCB+HF*	ASTM A217 Gr. WC6+HF*	ASTM A217 Gr. WC9+HF*
04	Seat Ring	ASTM A216 Gr. WCB+HF*	ASTM A217 Gr. WC6+HF*	ASTM A217 Gr. WC9+HF*
05	Hinge Pin	13% Cr. Steel		
06	Gasket	Graphite		
07	Stud	ASTM A193 Gr. B7		
08	Stud Nut	ASTM A194 Gr. 2H		
	Nameplate	SS 304		

* HF - Seat Hard-Faced with Stellite #6 or equivalent

Dimensions (in mm, unless specified) & Weights (in kg)

Valve Size	Class 900			Class 1500			Class 2500		
	A	B	Approx. Wt.	A	B	Approx. Wt.	A	B	Approx. Wt.
50 (2")	-	-	-	216	240	35	279	240	40
80 (3")	-	-	-	305	275	45	368	240	55
100 (4")	-	-	-	406	275	62	457	300	80
150 (6")	-	-	-	559	310	110	610	360	180
200 (8")	-	-	-	711	415	250	762	485	320
250 (10")	-	-	-	864	500	435	914	615	945
300 (12")	-	-	-	991	605	600	1041	665	1135
350 (14")	991	630	780	1067	630	875	*	*	*
400 (16")	-	-	-	1194	750	*	*	*	*
500 (20")	-	-	-	*	*	*	-	-	-

* Refer to L&T

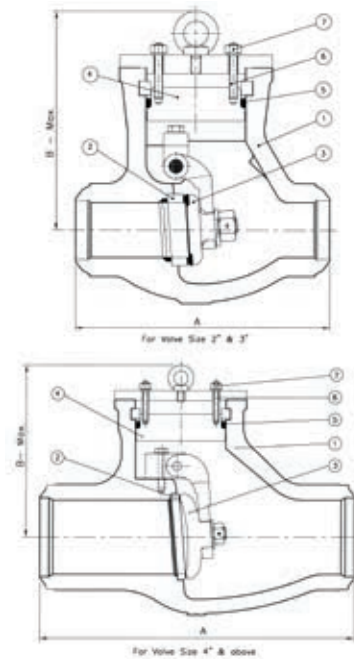

L&T Cryogenic Gate & Globe Valves

Services that handle fluids at sub-zero temperatures present several technical challenges. L&T's specially-adopted, extended-bonnet gate and globe valves provide the right solution for such low-temperature and cryogenic services.

L&T offers a range of gate and globe valves (as well as check valves) for low temperature and cryogenic services, used in processing, storage and transportation of liquefied gases such as Ethylene, LPG, LNG, Hydrogen, Helium, Oxygen, Nitrogen and Argon. Low temperature services of up to -46°C are covered by low-temperature carbon steels like LCB and LCC materials. Cryogenic services at -196°C are covered by stainless steel grades like CF8M and CF8.

L&T Cryogenic Gate and Globe Valves are available in ASME Class 150, Class 300 and Class 600 ratings. Refer page 3 for detailed manufacturing programme.

Extended Bonnet

Optional extended bonnet with vapour column length according to BS 6364 and / or customer specifications is furnished. The vapour column allows the stem packing to be functional by keeping it away from the cryogenic fluid.

Testing and Standards

L&T Cryogenic Valves are type-tested as per valve standards and specifications of leading oil companies as part of the design verification process.



Test facilities

L&T has Cryogenic test facilities for testing valves of temperatures as low as -196° in sizes from 50mm (2") to 1500mm (60"). This ranks one among the largest facilities worldwide.



Cryogenic Gate Valves - ASME Classes 150, 300 & 600

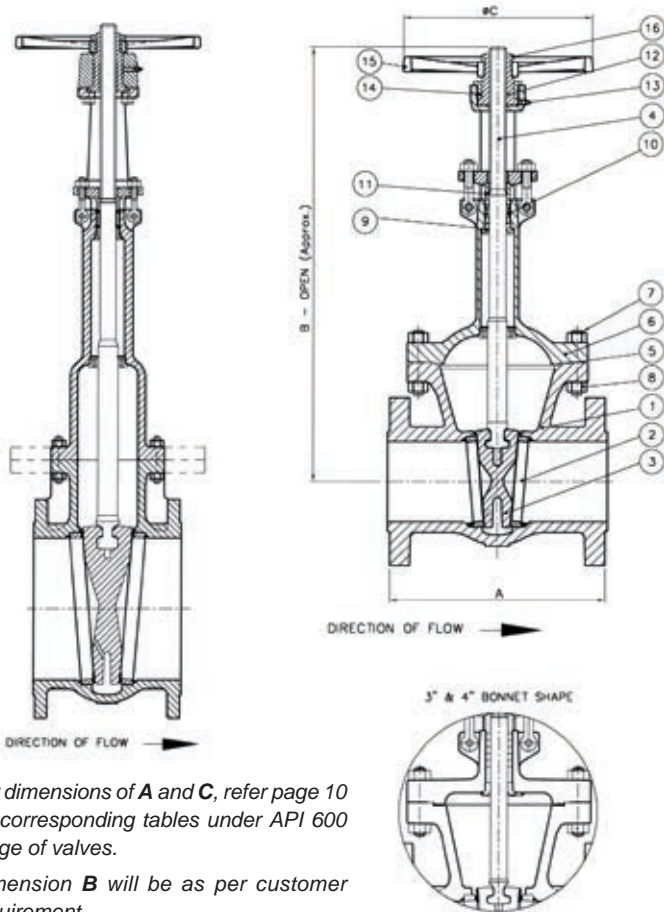

For dimensions of **A** and **C**, refer page 10 for corresponding tables under API 600 range of valves.

Dimension **B** will be as per customer requirement.

Parts List

Sl. No.	Description
01	Body
02	Body Seat Ring
03	Wedge
04	Stem
05	Gasket
06	Bonnet
07	Stud
08	Stud Nut
09	Back Seat
10	Packing
11	Gland
12	Yoke Sleeve
13	Grease Fitting
14	Retainer Nut
15	Handwheel
16	Handwheel Nut
	Nameplate

Materials of construction are selected, based on the service fluid, temperature and customer specifications.

Cryogenic Globe Valves - ASME Classes 150, 300 & 600

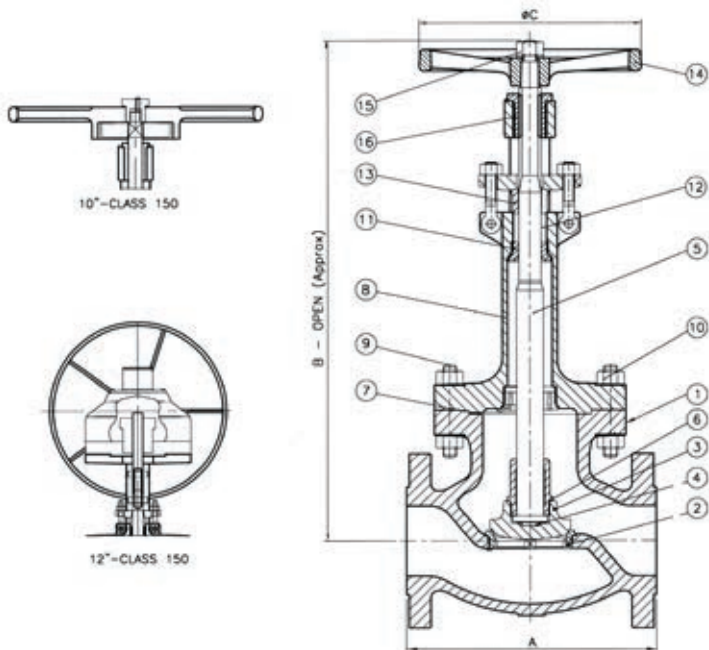

For dimensions of **A** and **C**, refer page 12 for corresponding tables under API 600 range of valves.

Dimension **B** will be as per customer requirement.

Parts List

Sl. No.	Description
01	Body
02	Body Seat Ring
03	Disc
04	Disc washer
05	Stem
06	Disc Stem Nut
07	Gasket
08	Bonnet
09	Stud
10	Stud Nut
11	Back Seat
12	Packing
13	Gland
14	Handwheel
15	Handwheel
16	Yoke Bush
	Nameplate

Materials of construction are selected, based on the service fluid, temperature and customer specifications.

Angle Globe Valves - ASME Class 150 & 300

L&T Cast Steel Angle Globe Valves are tight sealing, easy-to-operate regulation valves for liquid and gaseous fluids over a wide range of line pressures and temperatures.

Angle Globe Valves operate in a manner similar to that of a globe valve. However, the 90° angle between the inlet and outlet pipes greatly reduces the pressure drop across the valve as compared to a conventional globe valve. These valves are used for flow control especially in systems where valve geometry or pressure drop is a concern.

Body and Bonnet

The flow to the body outlet is streamlined by the smooth curvature of the inner surface which minimises the pressure drop across the flow path. The bonnet is fitted with a bonnet bush to guide the stem and provide for back seating when the valve is open and under pressure.

Disc and Stem

The disc provides a fine bearing on a taper seal for tight sealing over a wide range of differential pressures. As the seating between disc and body seat ring is a narrow line contact, tight sealing can be achieved even if any foreign particle gets stuck to the seating area. The disc and stem are held together by a disc nut with allowance for the disc to swivel. The disc has internal threads to receive the disc nut which retains the stem with the disc. A stem thrust plate is provided between the stem and the disc.

Body Seat Ring

A forged shoulder type body seat ring has threaded engagement with the body and a wide-tapered seating area. The body seat ring is tack welded to the body to prevent loosening. The seating surfaces are ground and lapped.



Test Pressures

Hydrostatic	Class 150		Class 300	
	bar	psig	bar	psig
Body	31	450	78	1125
Seat (Closure)	22	315	56	815
Back Seat	22	315	56	815

Materials of Construction

Sl. No.	Description	Material
01.	Body	ASTM A216 Gr. WCB
02.	Bonnet	ASTM A216 Gr. WCB
03.	Stem	ASTM A182 Gr. F6A/SS316/ AISI 410
04.	Disc	AISI 410 / ASTM A 217 Gr. CA15 / ASTM A216 Gr. WCB with Stellite
05.	Seat Ring	AISI 410 / ASTM A 217 Gr. CA15 / ASTM A182 Gr.F6a / ASTM A182 Gr. F6a + Stellite / ASTM A105 + Stellite
06.	Yoke Bush	ASTM A439 Type D2
07.	Stem Packing	Graphite
08.	Handwheel	SG Iron or Malleable Iron or Steel
09.	Gasket	SWG with Graphite filler only
10.	Back Seat Bush	AISI 410 / 420
11.	Studs	ASTM A193 Gr. B7
12.	Stud Nuts	ASTM A194 Gr. 2H

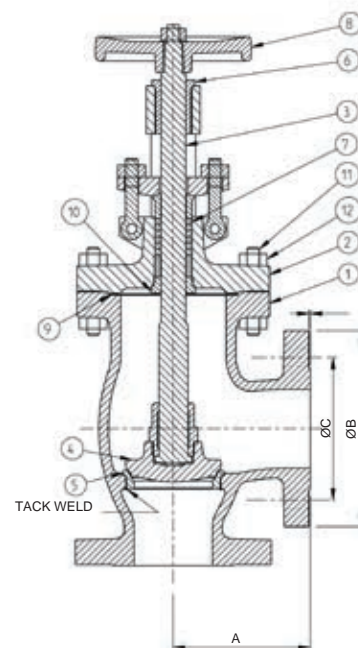

Dimensional Details (in mm, unless specified)

Valve Size		Class 150			Class 300		
mm	inches	A	B	C	A	B	C
50	2"	102	339.0	203.0	133	346.6	203.0
80	3"	121	423.9	254.0	159	465.5	254.0
100	4"	146	493.7	254.0	178	568.5	254.0
150	6"	203	560.5	356.0	222	680.5	457.0
200	8"	248	663.8	457.0	279	821.6	610.0
250	10"	311	790.7	610.0	311	917.5	762.0
300	12"	349	934.5	610.0	356	1200.2	762.0

End Connection

Offered with flanged and butt weld ends to the following standards :

- Flanged : ASME / ANSI B16.5 Raised Face (RF)
Serrated spiral to 125 to 250 Ra (AARH)
- Butt Weld : ASME / ANSI B16.25 to suit the corresponding pipe schedule

Standards

- Valve Design : BS 1873
- Shell Wall thickness : BS 1873
- Face to Face : ASME/ANSI B16.10

Pressure temperature

- Ratings : ASME/ANSI B16.34
- Pressure testing : API 598

Valves can also be offered with IBR Certification. * Gear-operated

L&T Special Valves

Live-loaded Valves

The stem packing system in a valve prevents leakage of line fluid to the atmosphere. The effectiveness of the sealing performance of the stem / gland packing depends on several factors such as dimensional tolerance and surface finish of the stem and packing chamber, packing material and its resilience, and packing pressure.

In a conventional valve, packing consolidation takes place and the packing pressure gets reduced in service, resulting in the possibility of leakage. Tightening of the gland nut restores the packing pressure and arrests possible leakage. This adjustment restores the effectiveness of the packing sealing.

In a live-loaded arrangement, the packing pressure or the load is maintained at a relatively constant level as the packing consolidates during service. Achieved by means of a set of Disc Springs or Belleville Springs that is installed between the gland flange and the gland stud, this creates additional elasticity in the gland loading system. The precompression load applied on the Disc Springs ensures that the load required for leak-tight sealing is exerted on the packing, even after relaxation or consolidation of packing. This continuous in-service self-adjustment results in superior stem sealing performance, particularly in services where pressure / temperature fluctuation or cycling is frequent.

Low-emission Service Valves

To comply with the requirements for Clean Air Act, L&T Cast Steel Valves have undergone extensive in-house testing, using Compressed Natural Gas (CNG) at the full-rated pressure as a test medium, as well as Helium in accordance with ISA standards.

Based on proven experience over the years, L&T has established appropriate design parameters and manufacturing methods to offer valves that meet stringent fugitive emission norms as per industry practices.

Salient features of these valves are :

- Gland Packing of high-purity, flexible graphite, sandwiched between braided graphite end-rings with Inconel wire mesh reinforcement. On request, gland packing with conical / wedge-shaped configuration can also be offered.
- Bonnet gasket in valves of ASME Class 150 is made of graphite-SS 316 insert. Valves of ASME Class 300 feature gaskets of spirally-wound stainless steel with graphite filler. In valves of ASME Class 600 and higher, metallic ring gaskets are offered.
- The stem finish is 16-32 RMS, with a straightness of 0.001" - 0.005" over the length of the plain shank. Cylindricity is controlled as per L&T standards.
- The Stuffing Box surface finish is 180 RMS max., and its straightness is controlled as per L&T standards.
- The diametrical clearances between the stem, gland and the stuffing box are controlled to close tolerances to ensure compliance with emission norms.

Valves for special services

L&T offers a wide variety of valves for special applications that call for additional design features and special testing.

- Valves for Hydrogen service which are pressure tested with Helium
- Valves for Dowtherm service
- Valves for sour gas services, conforming to NACE specifications of different Indian and overseas customers and consultants
- Valves for Chlorine service, having special trims like Monel or Hastelloy C
- Valves for nuclear applications requiring designs to withstand seismic disturbances, quick operation and special features to avoid external leakage to atmosphere
- Bellow Seal Gate and Globe valves
- Y-type Stop Check Valves

Soft-seated Valves

In applications that require positive shut-off such as in chemical and petrochemical services, the L&T Soft-seated Gate Valve is a suitable solution.

PTFE seat inserts provide the necessary soft-seating to ensure positive shut-off.

Salient features of these valves are :

- PTFE seat inserts for positive shut-off
- Block-and-Bleed capability
- Dual seating (metallic and soft seats)
- Intrinsically fire-safe
- Bubble-tight performance

All API 600 L&T gate valves can be offered with the option of soft-seating for sizes up to 10" (250mm).

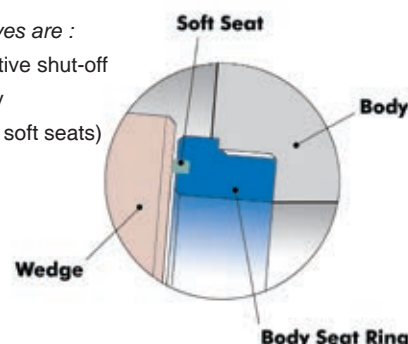

Pressure-Temperature Ratings - ASME B16.34, 1996

Temp in °F	Temp. in °C	Working Pressure in psig											
		ASTM A216 Gr. WCB** (Standard Class)						ASTM A217 Gr. WC6 (Standard Class)					
		#150	#300	#600	#900	#1500	#2500	#150	#300	#600	#900	#1500	#2500
-20 to 100	-28.9 to 37.7	285	740	1480	2220	3705	6170	290	750	1500	2250	3750	6250
200	93.3	260	675	1350	2025	3375	5625	260	750	1500	2250	3750	6250
300	148.9	230	655	1315	1970	3280	5470	230	720	1445	2165	3610	6015
400	204.4	200	635	1270	1900	3170	5280	200	695	1385	2080	3465	5775
500	260.0	170	600	1200	1795	2995	4990	170	665	1330	1995	3325	5540
600	315.5	140	550	1095	1640	2735	4560	140	605	1210	1815	3025	5040
650	343.3	125	535	1075	1610	2685	4475	125	590	1175	1765	2940	4905
700	371.7	110	535	1065	1600	2665	4440	110	570	1135	1705	2840	4730
750	398.9	95	505	1010	1510	2520	4200	95	530	1065	1595	2660	4430
800	426.6	80	410	825	1235	2060	3430	80	510	1015	1525	2540	4230
850	454.4	65	270	535	805	1340	2230	65	485	975	1460	2435	4060
900	482.2	50	170	345	515	880	1430	50	450	900	1350	2245	3745
950	510.0	35	105	205	310	515	860	35	320	640	955	1595	2655
1000	537.8	20	50	105	155	260	430	20	215	430	650	1080	1800
1050	565.5	-	-	-	-	-	-	*20	145	290	430	720	1200
1100	593.3	-	-	-	-	-	-	*20	95	190	290	480	800
1150	621.1	-	-	-	-	-	-	*20	60	125	185	310	515
1200	648.9	-	-	-	-	-	-	*15	40	75	115	190	315

Temp in °F	Temp. in °C	Working Pressure in psig											
		ASTM A216 Gr. WC9 (Standard Class)						ASTM A216 Gr. C5 (Standard Class)					
		#150	#300	#600	#900	#1500	#2500	#150	#300	#600	#900	#1500	#2500
-20 to 100	-28.9 to 37.7	290	750	1500	2250	3750	6250	290	750	1500	2250	3750	6250
200	93.3	260	750	1500	2250	3750	6250	260	745	1490	2235	3725	6205
300	148.9	230	730	1455	2185	3640	6070	230	715	1430	2150	3580	5965
400	204.4	200	705	1410	2115	3530	5880	200	705	1410	2115	3530	5880
500	260.0	170	665	1330	1995	3325	5540	170	665	1330	1995	3325	5540
600	315.5	140	605	1210	1815	3025	5040	140	605	1210	1815	3025	5040
650	343.3	125	590	1175	1765	2940	4905	125	590	1175	1765	2940	4905
700	371.7	110	570	1135	1705	2840	4730	110	570	1135	1705	2840	4730
750	398.9	95	530	1065	1595	2660	4430	95	530	1055	1585	2640	4400
800	426.6	80	510	1015	1525	2540	4230	80	510	1015	1525	2540	4230
850	454.4	65	485	975	1460	2435	4060	65	485	965	1450	2415	4030
900	482.2	50	450	900	1350	2245	3745	50	370	740	1110	1850	3085
950	510.0	35	375	755	1130	1885	3145	35	275	550	825	1370	2285
1000	537.8	20	260	520	780	1305	2170	20	200	400	595	995	1665
1050	565.5	*20	175	350	525	875	1455	*20	145	290	430	720	1200
1100	593.3	*20	110	220	330	550	915	*20	100	200	300	495	830
1150	621.1	*20	70	135	205	345	570	*20	60	125	185	310	515
1200	648.9	*20	40	80	125	205	345	*20	35	70	105	170	285

Temp in °F	Temp. in °C	Working Pressure in psig											
		ASTM A352 Gr. LCB (Standard Class)						ASTM A352 Gr. LCC (Standard Class)					
		#150	#300	#600	#900	#1500	#2500	#150	#300	#600	#900	#1500	#2500
-20 to 100	-28.9 to 37.7	265	695	1390	2085	3470	5785	290	750	1500	2250	3750	6250
200	93.3	250	655	1315	1970	3280	5470	260	750	1500	2250	3750	6250
300	148.9	230	640	1275	1915	3190	5315	230	730	1455	2185	3640	6070
400	204.4	200	620	1235	1850	3085	5145	200	705	1410	2115	3530	5880
500	260.0	170	585	1165	1745	2910	4850	170	665	1330	1995	3325	5540
600	315.5	140	535	1065	1600	2665	4440	140	605	1210	1815	3025	5040
650	343.3	125	525	1045	1570	2615	4355	125	590	1175	1765	2940	4905
700	371.7	110	520	1035	1555	2590	4320	110	570	1135	1705	2840	4730
750	398.9	95	475	945	1420	2365	3945	95	505	1010	1510	2520	4200
800	426.6	80	390	780	1175	1955	3260	80	410	825	1235	2060	3430
850	454.4	65	270	535	805	1340	2230	65	270	535	805	1340	2230
900	482.2	50	170	345	515	860	1430	50	170	345	515	860	1430
950	510.0	35	105	205	310	515	860	35	105	205	310	515	860
1000	537.8	20	50	105	155	260	430	20	50	105	155	260	430

Temp in °F	Temp. in °C	Working Pressure in psig											
		ASTM A351 Gr. CF8 (Standard Class)						ASTM A351 Gr. CF8M (Standard Class)					
		#150	#300	#600	#900	#1500	#2500	#150	#300	#600	#900	#1500	#2500
-20 to 100	-28.9 to 37.7	275	720	1440	2160	3600	6000	275	720	1440	2160	3600	6000
200	93.3	230	600	1200	1800	3000	5000	235	620	1240	1860	3095	5160
300	148.9	205	540	1080	1620	2700	4500	215	560	1120	1680	2795	4660
400	204.4	180	495	995	1490	2485	4140	195	515	1025	1540	2570	4280
500	260.0	170	465	930	1395	2330	3880	170	480	955	1435	2390	3980
600	315.5	140	435	875	1310	2185	3640	140	450	900	1355	2255	3760
650	343.3	125	430	860	1290	2150	3580	125	445	890	1330	2220	3700
700	371.7	110	425	850	1275	2125	3540	110	430	870	1305	2170	3620
750	398.9	95	415	830	1245	2075	3460	95	425	855	1280	2135	3560
800	426.6	80	405	805	1210	2015	3360	80	420	845	1265	2110	3520
850	454.4	65	395	790	1190	1980	3300	65	420	835	1255	2090	3480
900	482.2	50	390	780	1165	1945	3240	50	415	830	1245	2075	3460
950	510.0	35	380	765	1145	1910	3180	35	385	775	1160	1930	3220
1000	537.8	20	320	640	965	1605	2675	20	350	700	1050	1750	2915
1050	565.5	*20	-	615	925	1545	2570	*20	345	685	1030	1720	2865
1100	593.3	*20	255	515	770	1285	2145	*20	305	610	915	1525	2545
1150	621.1	*20	200	400	595	995	1655	*20	235	475	710	1185	1970
1200	648.9	*20	155	310	465	770	1285	*20	185	370	555	925	1545
1250	676.7	*20	115	225	340	565	945	*20	145	295	440	735	1230
1300	704.4	*20	85	170	255	430	715	*20	115	235	350	585	970
1350	732.2	*20	60	125	185	310	515	*20	95	190	290	480	800
1400	780.0	*20	50	95	145	240	400	*20	75	150	225	380	630
1450	787.8	*15	35	70	105	170	285	*20	60	115	175	290	485
1500	815.6	*10	25	55	80	135	230	*20	40	85	125	205	345

* For weld-end valves only. Flanged-end ratings terminate at 1000°F.
 ** Not recommended for prolonged use above 800°F (425°C).

* For weld-end valves only. Flanged-end ratings terminate at 1000°F.

Not to be used over 650°F.

* For weld-end valves only. Flanged-end ratings terminate at 1000°F.

Pressure-Temperature Ratings - ASME B16.34, 1996

Temp in °F	Temp. in °C	Working Pressure in psig					
		ASTM A217 Gr. C12 (Standard Class)					
		#150	#300	#600	#900	#1500	#2500
-20 to 100	-28.9 to 37.7	290	750	1500	2250	3750	6250
200	93.3	260	750	1500	2250	3750	6250
300	148.9	230	730	1455	2185	3640	6070
400	204.4	200	705	1410	2115	3530	5880
500	260.0	170	665	1330	1995	3325	5540
600	315.5	140	605	1210	1815	3025	5040
650	343.3	125	590	1175	1765	2940	4905
700	371.7	110	570	1135	1705	2840	4730
750	398.9	95	530	1065	1595	2660	4430
800	426.6	80	510	1015	1525	2540	4230
850	454.4	65	485	975	1460	2435	4060
900	482.2	50	450	900	1350	2245	3745
950	510.0	35	375	755	1130	1885	3145
1000	537.8	20	255	505	760	1270	2115
1050	565.5	*20	170	345	515	855	1430
1100	593.3	*20	115	225	340	565	945
1150	621.1	*20	75	150	225	375	630
1200	648.9	*20	50	105	155	255	430

* For weld-end valves only.
Flanged-end ratings terminate at 1000°F.

Temp in °F	Temp. in °C	Working Pressure in psig											
		ASTM A216 Gr. WCB** (Special Class)						ASTM A217 Gr. WC6 (Special Class)					
		#150	#300	#600	#900	#1500	#2500	#150	#300	#600	#900	#1500	#2500
-20 to 100	-28.9 to 37.7	290	750	1500	2250	3750	6250	290	750	1500	2250	3750	6250
200	93.3	290	750	1500	2250	3750	6250	290	750	1500	2250	3750	6250
300	148.9	290	750	1500	2250	3750	6250	290	750	1500	2250	3750	6250
400	204.4	290	750	1500	2250	3750	6250	290	750	1500	2250	3750	6250
500	260.0	290	750	1500	2250	3750	6250	290	750	1500	2250	3750	6250
600	315.5	275	715	1425	2140	3565	5940	290	750	1500	2250	3750	6250
650	343.3	270	700	1400	2100	3495	5825	290	750	1500	2250	3750	6250
700	371.7	265	695	1390	2080	3470	5780	280	735	1465	2200	3665	6110
750	398.9	240	630	1260	1890	3150	5250	280	730	1460	2185	3645	6070
800	426.6	200	515	1030	1545	2570	4285	275	720	1440	2160	3600	6000
850	454.4	130	335	670	1005	1670	2785	260	680	1355	2030	3385	5645
900	482.2	85	215	430	645	1070	1785	225	585	1175	1760	2935	4895
950	510.0	50	130	260	385	645	1070	155	400	795	1195	1995	3320
1000	537.8	25	65	130	195	320	535	105	270	540	810	1350	2250
1050	565.5	-	-	-	-	-	-	70	180	360	540	900	1500
1100	593.3	-	-	-	-	-	-	45	120	240	360	600	1000
1150	621.1	-	-	-	-	-	-	30	75	155	230	385	645
1200	648.9	-	-	-	-	-	-	20	45	95	140	235	395

* For weld-end valves only. Flanged-end ratings terminate at 1000°F.
** Not recommended for prolonged use above 800°F (425°C).

Temp in °F	Temp. in °C	Working Pressure in psig											
		ASTM A217 Gr. WC9 (Special Class)						ASTM A352 Gr. LCB@ (Special Class)					
		#150	#300	#600	#900	#1500	#2500	#150	#300	#600	#900	#1500	#2500
-20 to 100	-28.9 to 37.7	290	750	1500	2250	3750	6250	265	695	1390	2085	3470	5785
200	93.3	290	750	1500	2250	3750	6250	265	695	1390	2085	3470	5785
300	148.9	285	740	1485	2225	3705	6180	265	695	1390	2085	3470	5785
400	204.4	280	725	1450	2175	3620	6035	265	695	1390	2085	3470	5785
500	260.0	275	720	1440	2160	3600	6000	265	695	1390	2085	3470	5785
600	315.5	275	720	1440	2160	3600	6000	265	695	1390	2085	3470	5780
650	343.3	275	715	1430	2145	3580	5965	260	680	1360	2040	3400	5670
700	371.7	275	710	1425	2135	3555	5930	255	665	1185	1775	2960	4930
750	398.9	265	690	1380	2070	3450	5750	190	490	980	1465	2445	4070
800	426.6	260	675	1345	2020	3365	5605	130	335	670	1005	1670	2785
850	454.4	245	645	1285	1930	3215	5355	85	215	430	645	1070	1785
900	482.2	230	600	1200	1800	3000	5000	50	130	260	385	645	1070
950	510.0	180	470	945	1415	2355	3930	25	65	130	195	320	535
1000	537.8	125	325	650	975	1630	2715	-	-	-	-	-	-
1050	565.5	85	220	435	655	1095	1820	-	-	-	-	-	-
1100	593.3	55	135	275	410	685	1145	-	-	-	-	-	-
1150	621.1	35	85	170	255	430	715	-	-	-	-	-	-
1200	648.9	25	50	105	155	255	430	-	-	-	-	-	-

* For weld-end valves only. Flanged-end ratings terminate at 1000°F.
@ Not to be used over 650°F.

End Flange Dimensions - ASME 16.5, 1996

Valve Size	ASME Class 150 Raised Face (in mm)						ASME Class 300 Raised Face (in mm)							
	A Ø	B Ø	C Ø	D*	E Ø	Bolt		A Ø	B Ø	C Ø	D*	E Ø	Bolt	
						No.	Dia						No.	Dia
50 (2")	152	120	92	19.1 (15.9)	19	4	5/8"	165	127	92	22.3	19	8	5/8"
65 (2 1/2")	178	139	105	22.3 (17.5)	19	4	5/8"	190	149	105	25.4	22	8	3/4"
80 (3")	190	152	127	23.9 (19.1)	19	4	5/8"	210	168	127	28.6	22	8	3/4"
100 (4")	229	190	157	23.9	19	8	5/8"	254	200	157	31.8	22	8	3/4"
125 (5")	254	216	186	23.9	22	8	3/4"	279	235	186	35.0	22	8	3/4"
150 (6")	279	241	216	25.4	22	8	3/4"	318	270	216	36.6	22	12	3/4"
200 (8")	343	298	270	28.6	22	8	3/4"	381	330	270	41.3	25	12	7/8"
250 (10")	406	362	324	30.2	25	12	7/8"	444	387	324	47.7	29	16	1"
300 (12")	483	432	381	31.8	25	12	7/8"	521	451	381	50.8	32	16	1 1/8"
350 (14")	533	476	413	35.0	29	12	1"	584	514	413	54.0	32	20	1 1/8"
400 (16")	597	539	470	36.6	29	16	1"	648	571	470	57.2	35	20	1 1/4"
450 (18")	635	578	533	39.7	32	16	1 1/8"	711	628	533	60.4	35	24	1 1/4"
500 (20")	698	635	584	42.9	32	20	1 1/8"	775	686	584	63.5	35	24	1 1/4"
600 (24")	813	749	692	47.7	35	20	1 1/4"	914	813	692	69.9	41	24	1 1/2"

* Inclusive of raised face 1.6mm (0.06") each. Dimensions within brackets are for integral flanges

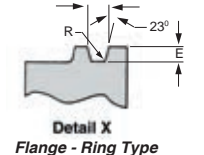
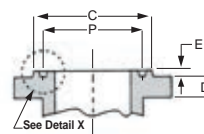
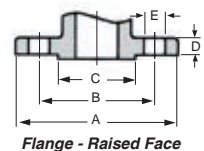

Large-sized End Flange Dimensions as per ASME 16.47, 1996 Series A (MSS SP 44)

ASME Class	Valve Size	A Ø	B Ø	C Ø	D*	E Ø	Bolt	
							No.	Dia
CL. 150	700 (28")	927	864	800	71	35	28	1 3/8"
	750 (30")	984	914	857	75	35	28	1 3/8"
	850 (34")	1111	1029	965	83	41	32	1 1/2"
	900 (36")	1168	1086	1022	90	41	32	1 1/2"
	1050 (42")	1346	1257	1194	97	41	36	1 1/2"
CL. 300	1200 (48")	1511	1422	1359	108	44	44	1 1/2"
	750 (30")	1092	997	857	95	48	28	1 3/4"

* Inclusive of raised face 1.6mm (0.06") each.

Large-sized End Flange Dimensions as per ASME 16.47, 1996 Series B (API 605)

ASME Class	Valve Size	A Ø	B Ø	C Ø	D*	E Ø	Bolt	
							No.	Dia
CL. 150	700 (28")	837	795	762	48	22	40	3/4"
	750 (30")	887	846	813	51	22	44	3/4"
	850 (34")	1005	957	921	57	25	40	7/8"
	900 (36")	1057	1010	972	59	25	44	7/8"
	1050 (42")	1226	1171	1130	68	28	48	1"
	1200 (48")	1392	1335	1289	75	28	44	1 1/8"
CL. 300	750 (30")	991	921	845	94	41	36	1 3/8"

* Inclusive of raised face 1.6mm (0.06") each.

Valve Size	ASME Class 600 Raised Face (in mm)					Bolt	
	A Ø	B Ø	C Ø	D	E Ø	Bolt	
						No.	Dia
50 (2")	165	127	92	25.4	19	8	5/8"
65 (2 1/2")	190	149	105	28.6	22	8	3/4"
80 (3")	210	168	127	31.8	22	8	3/4"
100 (4")	273	216	157	38.1	25	8	7/8"
125 (5")	330	266	186	44.5	29	8	1"
150 (6")	356	292	216	47.7	29	12	1"
200 (8")	419	349	270	55.6	32	12	1 1/8"
250 (10")	508	432	324	63.5	35	16	1 1/4"
300 (12")	559	489	381	66.7	35	20	1 1/4"
350 (14")	603	527	413	69.9	38	20	1 3/8"
400 (16")	686	603	470	76.2	41	20	1 1/2"
450 (18")	743	654	533	82.6	45	20	1 5/8"
500 (20")	813	724	584	88.9	45	24	1 5/8"
600 (24")	940	838	692	102.0	51	24	1 7/8"

Height of raised face is 6.4 mm (0.25") each.

Valve Size	ASME Class 600 Ring Type (in mm)								
	A Ø	B Ø	C Ø	D	Grv. No.	Pitch Ø - P	Depth E	Width F	Bottom Rad. R
50 (2")	165	127	108	25.4	R23	83	8.0	12.0	0.76
65 (2 1/2")	190	149	127	28.6	R26	100	8.0	12.0	0.76
80 (3")	210	168	146	31.8	R31	124	8.0	12.0	0.76
100 (4")	273	216	171	38.1	R37	150	8.4	8.7	0.76
125 (5")	330	266	209	44.5	R41	181	8.0	12.0	0.76
150 (6")	356	292	241	47.7	R45	211	8.0	12.0	0.76
200 (8")	419	349	302	55.6	R49	270	8.0	12.0	0.76
250 (10")	508	432	356	63.5	R53	324	8.0	12.0	0.76
300 (12")	559	489	413	66.7	R57	381	8.0	12.0	0.76
350 (14")	603	527	457	69.9	R61	419	8.0	12.0	0.76
400 (16")	686	603	508	76.2	R65	470	8.0	12.0	0.76
450 (18")	743	654	575	82.6	R69	533	8.0	12.0	0.76
500 (20")	813	724	635	88.9	R73	584	9.5	13.5	1.52
600 (24")	940	838	749	101.6	R77	692	11.1	16.6	1.52

Height of raised face is 6.4 mm (0.25") each. Grv. - Groove

Valve Size	ASME Class 900 Raised Face (in mm)					Bolt	
	A Ø	B Ø	C Ø	D	E Ø	Bolt	
						No.	Dia
50 (2")	216	165	92	38.1	25.4	8	7/8"
65 (2 1/2")	244	191	105	41.1	28.4	8	1"
80 (3")	241	191	127	38.1	25.4	8	7/8"
100 (4")	292	235	157	44.5	31.8	8	1 1/8"
125 (5")	349	279	186	50.8	35.1	8	1 1/4"
150 (6")	381	318	216	55.6	31.8	12	1 1/8"
200 (8")	470	394	270	63.5	38.1	12	1 3/8"
250 (10")	546	470	324	69.9	38.1	16	1 3/8"
300 (12")	610	533	381	79.2	38.1	20	1 3/8"

Height of raised face is 6.4 mm (0.25") each.

Valve Size	ASME Class 900 Ring Type (in mm)								
	A Ø	B Ø	C Ø	D	Grv. No.	Pitch Ø - P	Depth E	Width F	Bottom Rad. R
50 (2")	216	185	124	38.1	R24	95	8.0	12.0	0.76
65 (2 1/2")	244	191	137	41.1	R27	108	8.0	12.0	0.76
80 (3")	241	191	146	38.1	R31	124	8.0	12.0	0.76
100 (4")	292	235	171	44.5	R37	149	8.0	12.0	0.76
125 (5")	349	279	209	50.8	R41	181	8.0	12.0	0.76
150 (6")	381	318	241	55.8	R45	211	8.0	12.0	0.76
200 (8")	470	394	308	63.5	R49	270	8.0	12.0	0.76
250 (10")	546	470	362	69.9	R53	324	8.0	12.0	0.76
300 (12")	610	533	419	79.2	R57	381	8.0	12.0	0.76

Height of raised face is 6.4 mm (0.25") each. Grv. - Groove

Valve Size	ASME Class 1500 Raised Face (in mm)					Bolt	
	A Ø	B Ø	C Ø	D	E Ø	Bolt	
						No.	Dia
50 (2")	216	165	92	38.1	25.4	8	7/8"
65 (2 1/2")	244	191	105	41.1	28.4	8	1"
80 (3")	267	203	127	47.8	31.8	8	1 1/8"
100 (4")	311	241	157	53.8	35.1	8	1 1/4"
125 (5")	375	292	186	73.2	41.1	8	1 1/2"
150 (6")	394	318	216	82.6	38.1	12	1 3/8"
200 (8")	483	394	270	91.9	44.5	12	1 3/8"
250 (10")	584	483	324	108.0	50.8	12	1 3/8"
300 (12")	673	572	381	124.0	53.8	16	2"

Height of raised face is 6.4 mm (0.25") each.

Valve Size	ASME Class 1500 Ring Type (in mm)								
	A Ø	B Ø	C Ø	D	Grv. No.	Pitch Ø - P	Depth E	Width F	Bottom Rad. R
50 (2")	216	185	124	38.1	R24	95	8.0	12.0	0.76
65 (2 1/2")	244	191	137	41.1	R27	108	8.0	12.0	0.76
80 (3")	241	191	146	38.1	R31	124	8.0	12.0	0.76
100 (4")	292	235	171	44.5	R37	149	8.0	12.0	0.76
125 (5")	349	279	209	50.8	R41	181	8.0	12.0	0.76
150 (6")	381	318	241	55.8	R45	211	8.0	12.0	0.76
200 (8")	470	394	308	63.5	R49	270	8.0	12.0	0.76
250 (10")	546	470	362	69.9	R53	324	8.0	12.0	0.76
300 (12")	610	533	419	79.2	R57	381	8.0	12.0	0.76

Height of raised face is 6.4 mm (0.25") each. Grv. - Groove

Butt-weld End Details & Dimensions - ASME B16.25, 1997

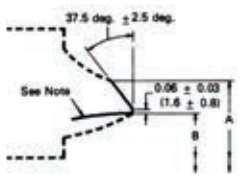

Welding end detail for joint without backing ring

Intended for use on 22mm (0.88") and thinner nominal wall thickness.

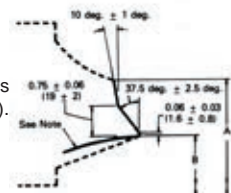

Intended for use on wall thickness greater than 22mm (0.88").

Note : Internal surface may be reformed or machined for dimensions B at root face. Contour within the envelope is manufacturer's option, unless otherwise specifically ordered for.

Nominal Pipe Size	A	B										
		STD	XS	30	40	60	80	100	120	140	160	XXS
65 (2 1/2")	75	-	-	-	63	-	59	-	-	-	54	45
80 (3")	91	-	-	-	78	-	74	-	-	-	67	58
100 (4")	117	-	-	-	102	-	97	-	92	-	87	80
125 (5")	144	-	-	-	128	-	122	-	116	-	110	103
150 (6")	172	-	-	-	154	-	148	-	140	-	132	124
200 (8")	223	-	-	-	203	198	194	189	183	178	173	175
250 (10")	278	-	-	-	255	247	242	237	230	222	216	-
300 (12")	329	305	298	-	303	295	289	281	273	267	257	-
350 (14")	362	337	330	-	333	325	318	308	300	292	284	-
400 (16")	413	387	-	-	381	373	364	354	344	333	325	-
450 (18")	464	438	432	-	429	419	410	398	387	378	367	-
500 (20")	516	489	483	-	478	467	456	443	432	419	408	-
600 (24")	619	591	584	581	575	560	548	532	518	505	491	-

Cast Steel - Material Characteristics

Element	ASTM Designation						
	Carbon Steel		Alloy Steel			Stainless Steel	
	A216 Gr. WCB	A352 Gr. LCC	A217 Gr. WC6	A217 Gr. WC9	A217 Gr. C5	A351 Gr. CF8	A351 Gr. CF8M
Carbon	\$0.30	0.25	0.05 - 0.20	0.05 - 0.18	0.20	0.08	0.08
Manganese	1.00	1.20	0.50 - 0.80	0.50 - 0.70	0.40 - 0.70	1.50	1.50
Phosphorus	0.04	0.04	0.04	0.04	0.04	0.04	0.04
Sulphur	0.045	0.045	0.045	0.045	0.05	0.04	0.04
Silicon	0.60	0.60	0.60	0.60	0.75	2.00	2.00
Copper	*0.30	0.30	*0.30	*0.50	*0.50	-	-
Nickel	*0.50	*0.50	*0.50	*0.50	*0.50	6.00 - 11.00	9.00 - 12.00
Chromium	*0.50	*0.50	1.00 - 1.50	2.00 - 2.75	4.00 - 6.50	18.00 - 21.00	18.00 - 21.00
Molybdenum	*0.20	*0.20	0.45 - 0.65	0.90 - 1.20	0.45 - 0.65	0.50	2.00 - 3.00
Vanadium	*0.30	*0.30	*0.30	-	-	-	-
Tungsten	-	-	*0.10	*0.30	*0.10	-	-

* Total content of these residual materials shall not exceed 1%. § L&T material standard is 0.25 max. Values indicated are all maximum, except when a range is specified.

Common Items - Material Characteristics

Element	Material						
	ASTM A194 Gr. B7	ASTM A320 Gr. L7	ASTM A194 Gr. 2H	ASTM A194 Gr. 7	Hardfacing Stellite #6	ASTM A182 Gr. F6a	ASTM A276 Type 316
Carbon	0.37 - 0.49	0.38 - 0.48	0.40 min	0.37 - 0.49	0.90 - 1.40	0.150	0.150
Manganese	0.65 - 1.10	0.75 - 1.00	1.00	0.65 - 1.10	1.00	1.000	2.000
Phosphorus	0.35	0.035	0.04	0.04	-	0.040	0.045
Sulphur	0.04	0.04	0.05	0.04	-	0.030	0.030
Silicon	0.15 - 0.35	0.15 - 0.35	0.40	0.15 - 0.35	2.00	1.000	1.000
Chromium	0.75 - 1.20	0.80 - 1.10	-	0.75 - 1.20	26.0 - 32.0	11.5 - 13.5	16.0 - 18.0
Molybdenum	0.15 - 0.25	0.15 - 0.25	-	0.15 - 0.25	1.00	-	2.0 - 3.0
Nickel	-	-	-	-	3.00	0.500	10.0 - 14.0
Cobalt	-	-	-	-	balance	-	-
Tungsten	-	-	-	-	3.0 - 6.0	-	-
Iron	-	-	-	-	3.00	-	-
Nitrogen	-	-	-	-	-	-	-

L&T Valve Accessories

GEAR OPERATORS

L&T gate and globe valves are supplied with fully-enclosed bevel gear operators as a standard for sizes and class ratings as shown in the table below. Gear operators are available as an option in other sizes too.

Valve Type	ASME Class	API 600		ASME B16.34	
		Standard	Optional	Standard	Optional
Gate	150	24" & above	14" - 20"	-	-
	300	20" & above	14" - 18"	-	-
	600	16" & above	8" - 14"	-	-
	900	8" & above	-	10" & above	6" & 8"
	1500	6" & above	-	10" & above	6" & 8"
	2500	-	-	8" & above	6"
Globe	150	10" & above	-	-	-
	300	10" & above	-	-	-
	600	6" & above	-	-	-
	900	-	-	-	-
	1500	-	-	-	-

ELECTRICAL ACTUATORS

Electrical Actuators may be used with L&T valves in all sizes and class ratings. The actuators can be operated in practically any position or location, and have a provision for manual operation. The actuators come in weatherproof enclosure as a standard, and in explosion-proof and such other special enclosures too. *For correct selection of actuator, please specify details of line pressure, differential pressure when closed, power supply requirements and actuator accessories.*



BYPASS ARRANGEMENT

A bypass arrangement serves two purposes - first, in steam services, to warm up the line before opening the main valve, and secondly, in steam and other lines, to balance the pressure on both sides of the main valve wedge or disc to bring down the valve opening torque.

As an option, almost all L&T valves can be furnished with bypass arrangement. The bypass consists of a single Outside Screw & Yoke globe valve with a pressure/temperature rating and corrosion resistance equal to or exceeding that of the main valve.

Size Chart

Main valve	2" to 4"	5" to 8"	10" or higher
Bypass valve	1/2"	3/4"	1"

The bypass valve is attached to the side of the main valve with the stems of both the valves in parallel and pointing upward.

Where service conditions warrant larger-than-standard bypasses, it is recommended that the installation of the bypasses be around the main valve.

CHAIN WHEELS

Chain wheels are used for the valves located too far above the floor for convenient handwheel operation. Chain wheels are available for all types of L&T Cast Steel Valves and can be substituted in place of or used along with the existing handwheel. L&T chain wheels are equipped with guards or guides, not only to keep the chain from slipping off the wheel but also to hold the chain in close contact with a large portion of the circumference of the handwheel or the gear wheel.

LANTERN RING

As mentioned earlier in page 7, a lantern ring is used to provide further integrity to the gland packing area in gate and globe valves, to prevent escape of service fluid to the atmosphere. This finds application in stringent environmental conditions or in the case of potentially harmful service fluids.

The lantern ring is provided between two sets of packing rings, with a leakoff plug that gives the option of removal of leakage, if any, from the lower packing rings. Alternatively, a sealing fluid can be introduced through the plug to prevent incidental leakage through the lower packing rings.

Lantern rings serve a useful purpose. But, since they are a possible source of shaft scoring, it is advisable to restrict their usage to essential applications.

POSITION INDICATORS

Valves can be provided with position indicators as a visible means to indicate the 'open' and 'closed' positions. Typically, for gate valves, the indicator is in the form of a pointer travelling along a fixed scale.

LOCKING DEVICES

Locking devices are used to secure a handwheel in a fixed position, to prevent accidental or unauthorized operation of a valve. The locking arrangement typically allows the use of chain and padlock to secure the valve.

sales@apsales.in