

Double Block & Bleed Plug Valves



L&T Valves

L&T Valves Limited, a wholly owned subsidiary of Larsen & Toubro, manufactures a comprehensive range of Double Block & Bleed Plug Valves in sizes up to 30" (750 mm), and in ASME classes 150 and 300. The valves are offered in a combination of materials, end-connections, actuation options, etc. to suit customer requirements.

Double Block & Bleed Plug Valve provides online-verifiable high-integrity positive shut-off, and is a safe and reliable replacement for the old two-valve system. Globally, the valve has emerged as the industry standard for movement and storage of petroleum products in refineries, tank farms and terminals.

Compliance Standards

Parameter	Standard
Design	API 6D/ ISO 14313
Pressure-Temperature Rating	ASME B16.34
Face-to-Face	API 6D from 2" to 12" ASME B16.10 from 14" to 18" Manufacturer standard for 20" and above
End Flanges	ASME B16.5, ASME B16.47
Actuator/ Gear Mounting	ISO 5211
Pressure Testing	API 6D
Fire Test	API 607/ ISO 10497
Fugitive Emission	ISO 15848-Part1

Material of Construction

Components	Materials
Body	ASTM A216 Gr WCB/ WCC + ENP
Plug	ASTM A216 Gr WCB/ WCC + ENP
Segment	ASTM A395 Gr 60-40-18
Seal	Viton
Bonnet	ASTM A216 Gr WCB/ WCC
Bearing	Stainless Steel backed PTFE
Packing	Die Moulded Graphite
O-Ring	Viton B
Drain Plug	SS 410
Bottom Cover	ASTM A216 Gr WCB/ WCC
Gasket	Die Moulded Graphite
Gland Flange	ASTM A216 Gr WCB/ WCC
Outer Stem	ASTM A479 Type 410
Inner Stem	ASTM A479 Type 410 Cond 3
Stud	ASTM A193 Gr B7
Hex Nut	ASTM A194 Gr 2H
Cavity Pressure Relief System	SS 316

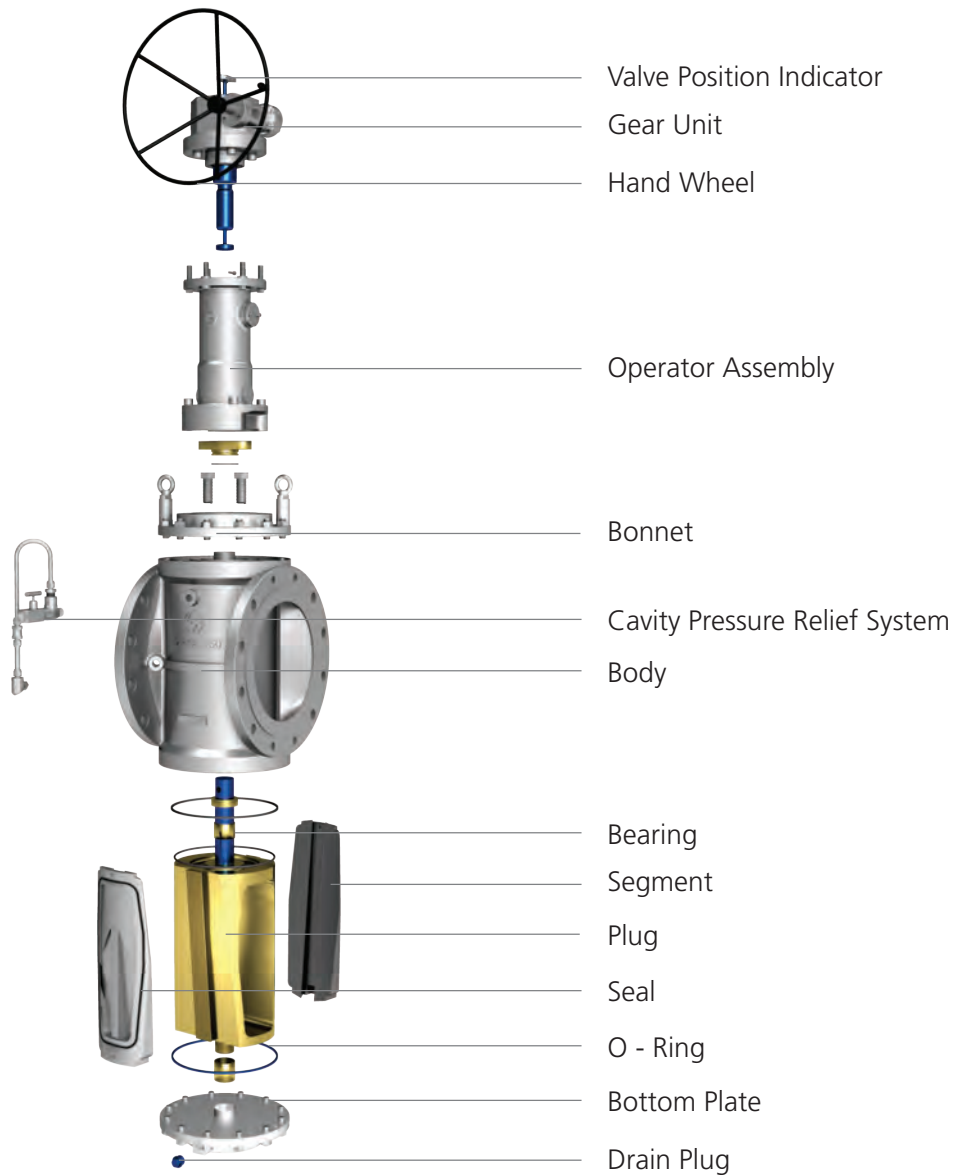

Features and Benefits

- Mechanically-assisted sealing - Reliable bubble-tight shut-off at low and high pressures.
- Non-lubricated valve - Sealant not required to achieve zero leakage
- Unique valve operation mechanism - Segments do not rub against seats during plug rotation
- Cavity Relief System - Prevents body cavity pressure build-up. Pressure relieved to upstream or downstream based on customer requirement
- On-line maintenance - Segments can be replaced on line
- Fire-Safe
- Vent is provided for online verification/ and drain is provided for draining the cavity

Double Block & Bleed Plug Valves - ASME Class 150

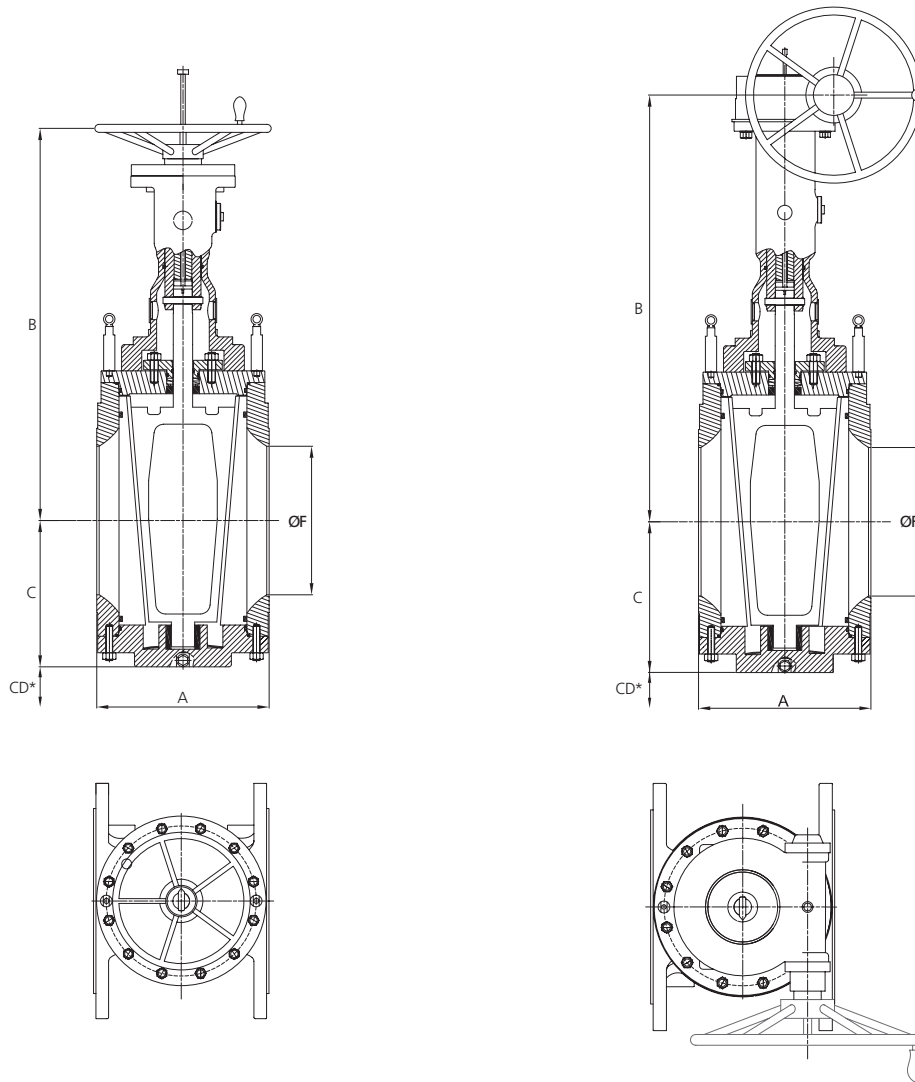

Dimensions

Size		A	B	C	CD*	F	No. & Size of Tapped Holes in Each Flange	Weight
NPS	DN							
2	50	178	456	152	85	49	-	40
3	80	203	471	175	99	74	-	50
4	100	229	487	191	139	100	(4) 5/8" - 11 UNC - 2B	62
6	150	267	637	225	199	150	(4) 5/8" - 11 UNC - 2B	145
8	200	292	672	261	256	201	(4) 3/4" - 10 UNC - 2B	195
10	250	330	709	290	337	252	(4) 7/8" - 9 UNC - 2B	245
12	300	356	784	328	424	303	(4) 7/8" - 9 UNC - 2B	360
14	350	381	801	377	466	334	(4) 1" - 8 UNC - 2B	445
16	400	406	1075	410	533	385	(4) 1" - 8 UNC - 2B	665
18	450	432	1103	438	589	436	(4) 1 1/8" - 8 UN - 2B	755
20	500	813	1137	493	668	487	(4) 1 1/8" - 8 UN - 2B	1070
24	600	914	1214	572	820	589	(4) 1 1/4" - 8 UN - 2B	1500
30	750	1524	1837	704	1033	735	(8) 1 1/4" - 8 UN - 2B	2965

All dimensions in mm and weights in kg

*Minimum Clearance for Segment Removal

Double Block & Bleed Plug Valves - ASME Class 300

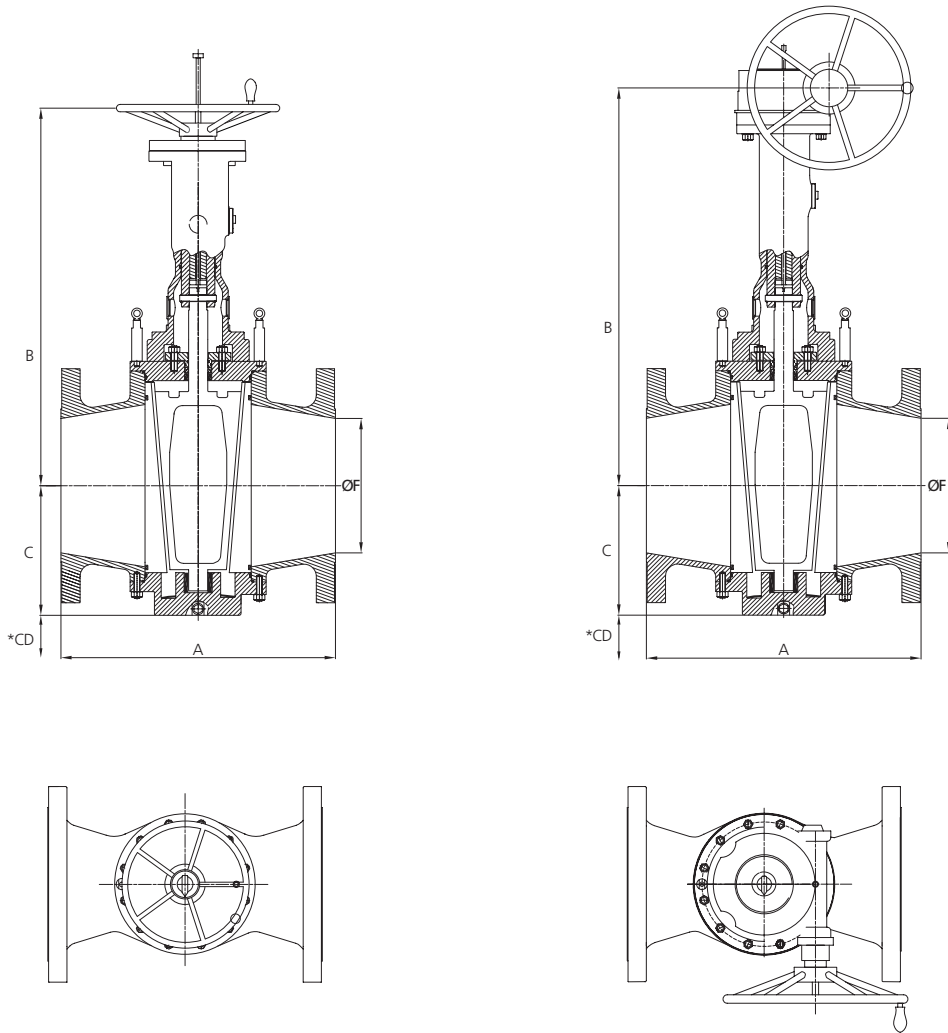

Dimensions

Size		A	B	C	CD*	F	No. & Size of Tapped Holes in Each Flange	Weight
NPS	DN							
2	50	216	456	152	85	49	-	45
3	80	283	471	175	99	74	-	55
4	100	305	487	191	139	100	-	75
6	150	403	637	225	199	150	-	175
8	200	419	672	261	256	201	-	235
10	250	457	709	270	327	252	(4) 1" - 8 UNC - 2B	315
12	300	502	776	346	414	303	(4) 1 1/8" - 8 UNC - 2B	450
14	350	762	826	396	464	334	(4) 1 1/8" - 8 UNC - 2B	880
16	400	838	876	446	514	385	(4) 1 1/4" - 8 UNC - 2B	1150
18	450	914	926	496	564	436	(4) 1 1/4" - 8 UNC - 2B	1500
20	500	991	976	546	614	487	(4) 1 1/4" - 8 UNC - 2B	1800
24	600	1321	1026	596	664	589	(4) 1 1/2" - 8 UN - 2B	2250

All dimensions in mm and weights in kg

*Minimum Clearance for Segment Removal

L&T Valves

L&T Valves Limited (Formerly Audco India Limited) is a wholly owned subsidiary of Larsen & Toubro. Backed by a fifty-year track-record of excellence and world-leading innovation, the company provides engineered flow-control solutions for key sectors of the economy such as oil & gas, power, petrochemicals, chemicals, fertilizers and pharmaceuticals.

The valves are designed using state-of-the-art 3D design, simulation and analysis software. Finite Element Analysis (FEA) and Computational Fluid Dynamics (CFD) are used to fine-tune product performance. Rigorous prototype tests-both in-house and at advanced flow control research establishments-ensure that the customised solutions meet customer expectations.

L&T Valves Limited is synonymous with world-class manufacturing and quality assurance systems. Our plants have the agility and flexibility to deliver a wide variety of valves against time constraints and dynamic customer demands. International safety, health and environment standards govern every phase of the manufacturing process.

L&T Valves Limited distribution network spans the globe, partnering some of the largest valve distribution companies in the world. In India, L&T Valves Limited has a presence in all major industrial centres through a network of offices, authorised stockists, automation centres and service franchisees.

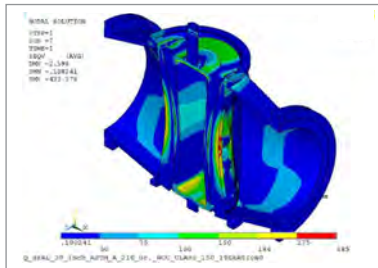

Larsen & Toubro is a USD 14 billion technology, engineering, construction, manufacturing and financial services conglomerate, with global operations. Its products and systems are marketed in over 30 countries worldwide. L&T is one of the largest and most respected companies in India's private sector. A strong, customer-focused approach and the constant quest for top-class quality have enabled L&T to attain and sustain leadership in its major lines of business over seven decades.

sales@apsales.in